

# V12

Open Spray Nozzles

## STYLE V12



SEE VICTAULIC PUBLICATION 10.01 FOR DETAILS

### MODEL NUMBERS

Nominal K-Factor	Available Deflector Angles							
1.2 (1.7 metric)	V1201 (180°)	V1202 (160°)	V1203 (140°)	V1204 (125°)	V1205 (110°)	V1206 (95°)	V1207 (80°)	V1208 (65°)
1.8 (2.6 metric)	V1211 (180°)	V1212 (160°)	V1213 (140°)	V1214 (125°)	V1215 (110°)	V1216 (95°)	V1217 (80°)	V1218 (65°)
2.3 (3.3 metric)	V1221 (180°)	V1222 (160°)	V1223 (140°)	V1224 (125°)	V1225 (110°)	V1226 (95°)	V1227 (80°)	V1228 (65°)
3.2 (4.6 metric)	V1231 (180°)	V1232 (160°)	V1233 (140°)	V1234 (125°)	V1235 (110°)	V1236 (95°)	V1237 (80°)	V1238 (65°)
4.1 (5.9 metric)	V1241 (180°)	V1242 (160°)	V1243 (140°)	V1244 (125°)	V1245 (110°)	V1246 (95°)	V1247 (80°)	V1248 (65°)
4.9 (7.1 metric)	V1251 (180°)	V1252 (160°)	V1253 (140°)	V1254 (125°)	V1255 (110°)	V1256 (95°)	V1257 (80°)	V1258 (65°)
5.6 (8.1 metric)	V1261 (180°)	V1262 (160°)	V1263 (140°)	V1264 (125°)	V1265 (110°)	V1266 (95°)	V1267 (80°)	V1268 (65°)
7.2 (10.4 metric*)	V1271 (180°)	V1272 (160°)	V1273 (140°)	V1274 (125°)	V1275 (110°)	V1276 (95°)	V1277 (80°)	V1278 (65°)

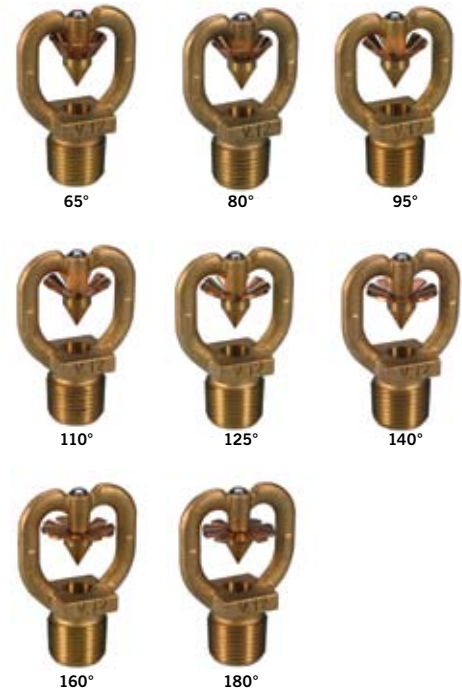

Victaulic V12 Spray Nozzles are open type spray nozzles designed for directional spray applications in fixed fire protection systems. They have an open design only (non-automatic) with a deflector that discharges a solid uniform cone spray of low- to medium- velocity water droplets. Victaulic V12 Spray Nozzles are available in multiple orifice sizes and spray angles to meet various design application requirements.

For nozzles having nominal U.S. K-Factors of 1.2, 1.8, 2.3, and 3.2, a bushing is used, whereas nozzles with K-Factors of 4.1, 4.9, 5.6, and 7.2 are machined orifices.

Nozzles are shown in the upright position for clarity. May be installed in any position to meet design requirements. K5.6 versions shown.

### NOZZLE APPLICATIONS:

Victaulic V12 Spray Nozzles are designed to apply cooling water to exposed vertical, horizontal, curved, and irregular shaped surfaces to allow cooling of objects externally when exposed to an adjacent fire. Cooling is done to prevent objects from absorbing heat that could cause structural damage and possible spread of fire to the protected object. In some applications, Victaulic V12 Spray Nozzles may be applied to control or extinguish fire of the protected area (depending on water design application density).

<b>JOB/OWNER</b>	<b>CONTRACTOR</b>	<b>ENGINEER</b>
System No. _____	Submitted By _____	Spec Sect _____ Para _____
Location _____	Date _____	Approved _____
		Date _____

# V12

Open Spray Nozzles

## STYLE V12

### TECHNICAL SPECIFICATIONS:

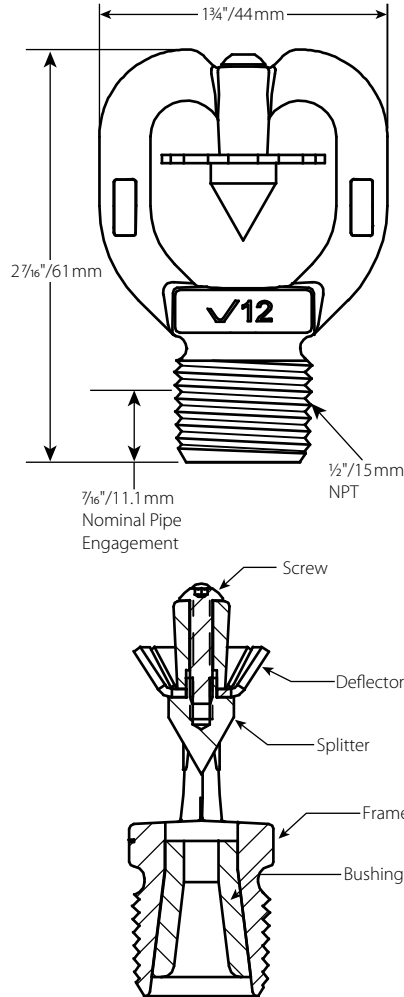

### SPECIFICATIONS:

**Minimum Operating Pressure:** Pendent Position (vertically downward) 10 psi/0.7 bar. All other positions 20 psi/1.4 bar

**Maximum Working Pressure:** 175 psi/12 bar

**Thread size:** 1/2\"/>

Nominal K-Factor	Available Deflector Angles							
	V1201 (180°)	V1202 (160°)	V1203 (140°)	V1204 (125°)	V1205 (110°)	V1206 (95°)	V1207 (80°)	V1208 (65°)
1.2 (1.7 metric)	V1201 (180°)	V1202 (160°)	V1203 (140°)	V1204 (125°)	V1205 (110°)	V1206 (95°)	V1207 (80°)	V1208 (65°)
1.8 (2.6 metric)	V1211 (180°)	V1212 (160°)	V1213 (140°)	V1214 (125°)	V1215 (110°)	V1216 (95°)	V1217 (80°)	V1218 (65°)
2.3 (3.3 metric)	V1221 (180°)	V1222 (160°)	V1223 (140°)	V1224 (125°)	V1225 (110°)	V1226 (95°)	V1227 (80°)	V1228 (65°)
3.2 (4.6 metric)	V1231 (180°)	V1232 (160°)	V1233 (140°)	V1234 (125°)	V1235 (110°)	V1236 (95°)	V1237 (80°)	V1238 (65°)
4.1 (5.9 metric)	V1241 (180°)	V1242 (160°)	V1243 (140°)	V1244 (125°)	V1245 (110°)	V1246 (95°)	V1247 (80°)	V1248 (65°)
4.9 (7.1 metric)	V1251 (180°)	V1252 (160°)	V1253 (140°)	V1254 (125°)	V1255 (110°)	V1256 (95°)	V1257 (80°)	V1258 (65°)
5.6 (8.1 metric)	V1261 (180°)	V1262 (160°)	V1263 (140°)	V1264 (125°)	V1265 (110°)	V1266 (95°)	V1267 (80°)	V1268 (65°)
7.2 (10.4 metric*)	V1271 (180°)	V1272 (160°)	V1273 (140°)	V1274 (125°)	V1275 (110°)	V1276 (95°)	V1277 (80°)	V1278 (65°)

Orifice sizes are indicated by the K-Factor, which is marked on the deflector. Refer to the Nominal Discharge Curves on pages 5 and 7 for each nozzle at various operating residual pressures.

\* Metric K-Factor measurement shown is when pressure is measured in kPa. When pressure is measured in Bar, multiply the metric K-Factor shown by 10.0.

**Deflector:** Brass UNS-C51000

**Screw:** Stainless Steel UNS-S30400

### ACCESSORIES:

#### Sprinkler Wrenches:

**A. Standard Wrench:** V27 Open End

### FINISHES:

Plain Brass

Proprietary Nickel Teflon\* coating

\* Teflon is a registered trademark of Dupont Co.

**Overall Length:** 2 7/16\"/>

### MATERIAL SPECIFICATIONS

**Frame Casting:** Dezincification resistant die cast brass

**Splitter:** Brass UNS-C36000

**Bushing (for nozzles with 1.2, 1.8, 2.3, and 3.2 K-Factors):** Brass UNS-C36000

### APPROVALS/LISTINGS

cULus Listed: Category VGYZ



WARNING

**WARNING**

Victaulic V12 Spray Nozzles are manufactured and tested to meet the rigid requirements of the approving agency.

The nozzles are designed to be installed in accordance with recognized installation standards. Deviation from the standards or any alteration to the nozzle after it leaves the factory including, but not limited to: painting, plating, coating, or modification, may render the unit inoperative and will automatically nullify the approval and any guarantee made by Victaulic.

The Approval Chart shows listings and approvals of Victaulic V12 Spray Nozzles for use on water spray systems and water based deluge systems. The chart shows listings and approvals available at the time of printing. Other approvals may be in process.

Check with the manufacturer for any additional approvals.

## V12

Open Spray Nozzles

### STYLE V12

#### INSTALLATION

- A. Victaulic V12 Spray nozzles are to be installed in accordance with the latest edition of Victaulic technical data, the latest published standards of NFPA or other similar organizations, and also with the provisions of governmental codes, ordinances, and standards whenever applicable. The use of Victaulic V12 Spray Nozzles may be limited due to occupancy and hazard. Refer to the Authority Having Jurisdiction prior to installation.
- B. Spray nozzles are installed on fixed fire protection systems, such as deluge systems, where total flooding is required.
- C. See Victaulic publication I-40 for installation and maintenance instructions.  
**Note:** A system strainer is needed if orifice diameter is less than  $\frac{3}{8}$ "/9.4mm, which includes V12 spray nozzles of K-Factors 3.2, 2.3, 1.8 and 1.2.
- D. Spray nozzles must be inspected on a regular basis for corrosion, mechanical damage, obstructions, paint, etc. Where open spray nozzles are installed, verify that foreign materials (such as dust, dirt, etc.) do not restrict or plug the water spray. The frequency of inspections may vary due to corrosive atmospheres, water supplies, and activity around the device.

# V12

Open Spray Nozzles

STYLE V12

## INSTALLATION TECHNICAL DATA

FIGURE 1 – K FACTOR DISCHARGE CURVES

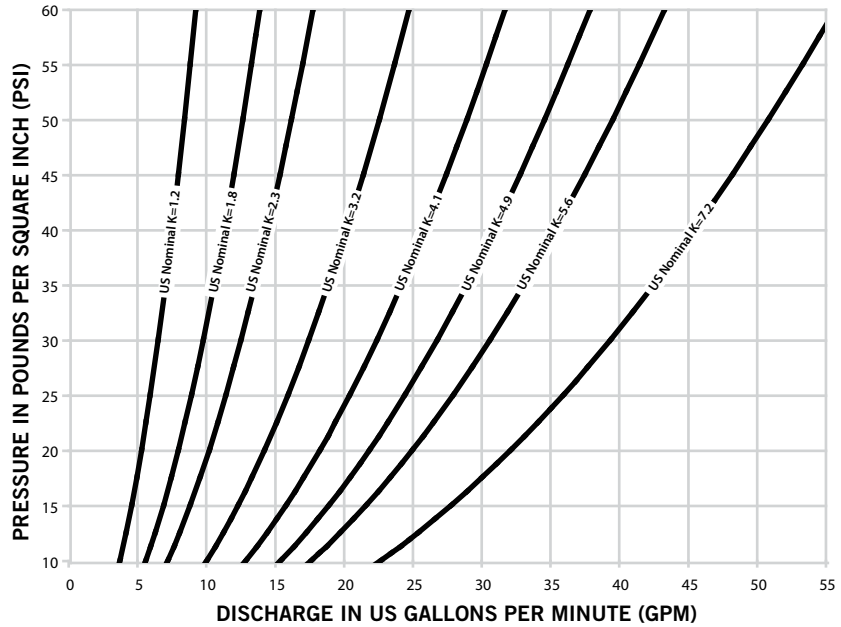

K-factors have tolerances of +/- 0.2 GPM/√PSI (0.2 LPM/√kPA) from nominal.

V12

Open Spray Nozzles

STYLE V12

INSTALLATION TECHNICAL DATA

FIGURE 2 – DESIGN SPRAY PROFILES (ALL K FACTORS)

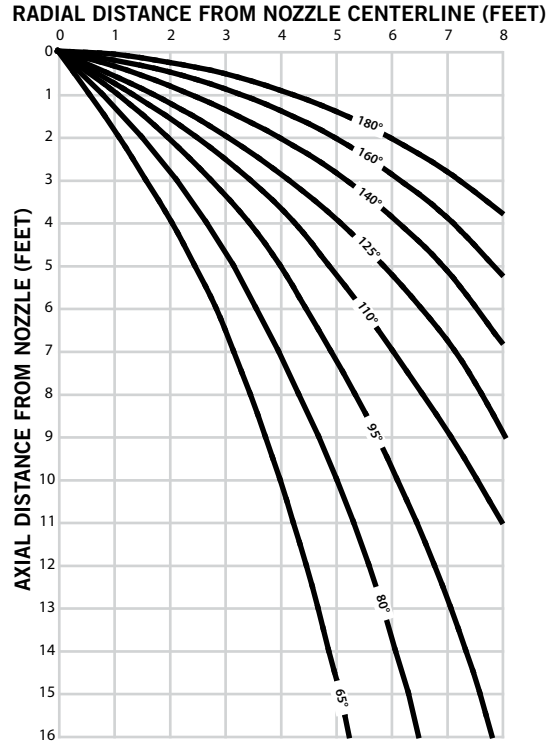

Notes:

- 1) The design spray profile is the included angle of discharge for each nozzle.
- 2) Figure 2 illustrates the radial distance at various heights based upon testing in the pendent position at 10 psi, 20 psi, and 60 psi / 69 kPa, 138 kPa, and 414 kPa discharge pressure (see Figure 3, Variable C).
- 3) For FM only installations, use a recommended tolerance of +/- 2 ft [0.6 m] from nominal for the radial distances shown (x-axis) in Figure 2 for all fixed angle orientations. Use a recommended spray profile angle tolerance of +/- 5° in the pendent position (vertically downward) and +/-10° in all other fixed angle orientations.
- 4) For UL/NFPA only installations, use a recommended tolerance of +/-15% from nominal for the radial distances shown (x-axis) in Figure 2 for all fixed angle orientations.
- 5) Spray profiles will tend to decrease (or pull inward) with an increase in pressure. All test data was obtained in a stagnant air environment.

See Exposure Protection Tables for fixed angle orientation and maximum axial distance from the plane of protection for each model.

# V12

Open Spray Nozzles

STYLE V12

## INSTALLATION TECHNICAL DATA EXPOSURE PROTECTION TABLES (IMPERIAL)

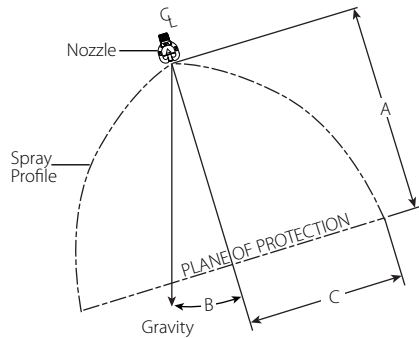

A – Axial Distance  
B – Fixed Angle (Orientation)  
C – Radial Distance

FIGURE 3 – SPRAY COVERAGE VARIABLES

MAXIMUM AXIAL DISTANCE FOR 65° SPRAY ANGLE IN FEET AND INCHES								
Fixed Angle	K FACTOR							
	1.2	1.8	2.3	3.2	4.1	4.9	5.6	7.2
0°	14-9	15-0	15-0	15-3	15-3	15-6	15-9	16-0
30°	9-9	9-9	10-0	10-3	10-6	10-9	11-0	11-6
45°	8-0	8-0	8-6	9-0	9-3	9-6	9-9	10-3
60°	7-0	7-3	7-9	8-3	8-6	8-6	8-9	9-6
90°	6-6	6-9	7-0	7-6	7-9	8-0	8-0	8-6
120°	6-3	6-6	6-9	7-3	7-3	7-6	7-6	7-9
135°	5-9	6-0	6-3	6-6	6-9	6-9	7-0	7-6
150°	5-6	5-9	6-0	6-0	6-6	6-9	6-9	7-3
180°	5-0	5-0	5-3	5-6	6-0	6-3	6-6	6-9

MAXIMUM AXIAL DISTANCE FOR 80° SPRAY ANGLE IN FEET AND INCHES								
Fixed Angle	K FACTOR							
	1.2	1.8	2.3	3.2	4.1	4.9	5.6	7.2
0°	14-9	15-0	15-0	15-3	15-3	15-6	15-9	16-0
30°	9-6	9-9	10-3	10-6	10-9	10-9	11-0	11-3
45°	7-6	7-9	8-3	8-6	8-9	9-0	9-3	9-9
60°	6-3	6-6	6-9	7-0	7-3	7-6	8-3	8-9
90°	5-9	6-3	6-6	6-9	7-0	7-3	7-6	7-9
120°	5-3	5-6	5-9	6-0	6-3	6-3	6-6	7-0
135°	4-9	5-3	5-6	5-9	6-0	6-0	6-3	6-6
150°	4-3	4-6	4-9	5-6	5-9	5-9	6-0	6-0
180°	4-0	4-3	4-6	5-3	5-6	5-6	5-9	5-9

MAXIMUM AXIAL DISTANCE FOR 95° SPRAY ANGLE IN FEET AND INCHES								
Fixed Angle	K FACTOR							
	1.2	1.8	2.3	3.2	4.1	4.9	5.6	7.2
0°	14-9	15-0	15-0	15-3	15-3	15-6	15-9	16-0
30°	8-3	8-6	9-3	9-6	10-3	10-6	10-6	11-3
45°	7-0	7-0	7-3	7-6	8-6	8-9	9-0	9-9
60°	5-3	5-6	5-9	6-6	6-9	7-0	7-6	8-6
90°	4-6	4-9	5-6	5-9	6-0	6-0	6-3	6-9
120°	4-0	4-3	4-6	5-0	5-3	5-6	5-6	5-9
135°	3-9	3-9	4-3	4-9	5-0	5-3	5-3	5-6
150°	3-3	3-6	3-6	4-6	4-9	4-9	5-0	5-3
180°	3-0	3-3	3-3	4-0	4-3	4-3	4-6	4-9

MAXIMUM AXIAL DISTANCE FOR 110° SPRAY ANGLE IN FEET AND INCHES								
Fixed Angle	K FACTOR							
	1.2	1.8	2.3	3.2	4.1	4.9	5.6	7.2
0°	9-6	9-9	9-9	10-0	10-3	10-6	10-9	11-0
30°	6-6	6-9	7-3	8-0	8-6	8-9	9-0	9-6
45°	5-6	6-0	6-9	7-0	7-6	7-9	8-3	8-6
60°	4-9	5-0	5-6	5-9	6-3	6-9	7-3	7-9
90°	3-9	4-0	4-6	4-9	5-3	5-6	5-9	6-3
120°	3-3	3-6	4-0	4-3	4-6	4-6	4-9	5-3
135°	2-9	3-0	3-6	4-0	4-3	4-3	4-6	4-9
150°	2-6	2-9	3-3	3-6	4-0	4-3	4-3	4-6
180°	2-3	2-6	3-0	3-3	3-6	3-9	4-0	4-3

MAXIMUM AXIAL DISTANCE FOR 125° SPRAY ANGLE IN FEET AND INCHES								
Fixed Angle	K FACTOR							
	1.2	1.8	2.3	3.2	4.1	4.9	5.6	7.2
0°	7-9	7-9	7-9	8-0	8-3	8-3	8-6	8-9
30°	5-0	5-3	5-6	5-9	6-9	7-3	7-9	7-9
45°	4-3	4-6	4-9	5-0	6-0	6-3	6-6	7-0
60°	3-6	3-9	4-0	4-3	5-3	5-6	5-9	6-3
90°	3-0	3-3	3-6	3-6	4-3	4-6	4-9	5-3
120°	2-0	2-0	2-6	3-3	3-9	3-9	3-9	4-3
135°	1-9	1-9	2-3	3-0	3-6	3-6	3-6	3-9
150°	1-6	1-9	2-3	2-6	3-0	3-3	3-3	3-6
180°	1-3	1-6	2-0	2-6	2-9	2-9	3-0	3-3

MAXIMUM AXIAL DISTANCE FOR 140° SPRAY ANGLE IN FEET AND INCHES								
Fixed Angle	K FACTOR							
	1.2	1.8	2.3	3.2	4.1	4.9	5.6	7.2
0°	6-3	6-3	6-3	6-6	6-6	6-6	6-9	6-9
30°	3-9	3-9	4-3	4-9	5-3	5-3	5-6	5-9
45°	3-0	3-3	3-6	4-3	4-9	5-0	5-0	5-3
60°	2-3	2-6	2-9	3-9	4-3	4-3	4-6	4-9
90°	2-0	2-0	2-6	3-0	3-6	3-9	3-9	4-0
120°	1-9	1-9	2-3	2-6	2-9	2-9	3-0	3-6
135°	1-6	1-6	1-9	2-3	2-6	2-6	2-9	3-0
150°	1-3	1-3	1-6	1-9	2-0	2-0	2-3	2-6
180°	1-0	1-0	1-3	1-6	1-9	1-9	2-0	2-3

MAXIMUM AXIAL DISTANCE FOR 160° SPRAY ANGLE IN FEET AND INCHES								
Fixed Angle	K FACTOR							
	1.2	1.8	2.3	3.2	4.1	4.9	5.6	7.2
0°	4-9	4-9	4-9	5	5	5	5-3	5-3
30°	3-9	3-9	4-0	4-0	4-6	4-6	4-6	4-9
45°	3-0	3-0	3-6	3-9	4-0	4-0	4-0	4-3
60°	2-0	2-0	2-3	2-6	3-3	3-3	3-6	3-6
90°	1-0	1-3	1-9	2-0	2-6	2-6	2-6	2-9
120°	NR	1-0	1-6	1-9	2-0	2-3	2-3	2-6
135°	NR	NR	1-0	1-6	1-9	1-9	1-9	2-0
150°	NR	NR	NR	1-0	1-3	1-3	1-6	1-9
180°	NR	NR	NR	1-0	1-0	1-0	1-3	1-6

MAXIMUM AXIAL DISTANCE FOR 180° SPRAY ANGLE IN FEET AND INCHES								
Fixed Angle	K FACTOR							
	1.2	1.8	2.3	3.2	4.1	4.9	5.6	7.2
0°	3-3	3-3	3-3	3-6	3-6	3-9	3-9	3-9
30°	2-3	2-3	2-6	2-9	3-0	3-3	3-3	3-3
45°	2-0	2-0	2-3	2-6	2-9	3-0	3-0	3-0
60°	1-6	1-6	1-9	2-0	2-3	2-3	2-6	2-6
90°	NR	NR	1-0	1-0	1-6	1-9	2-0	2-3
120°	NR	NR	1-0	1-0	1-3	1-6	1-6	1-9
135°	NR	NR	NR	1-0	1-0	1-3	1-3	1-6
150°	NR	NR	NR	NR	1-0	1-0	1-3	1-3
180°	NR	NR	NR	NR	NR	1-0	1-0	1-0

V12

Open Spray Nozzles

STYLE V12

INSTALLATION TECHNICAL DATA

FIGURE 4 – K FACTOR DISCHARGE CURVES (METRIC)

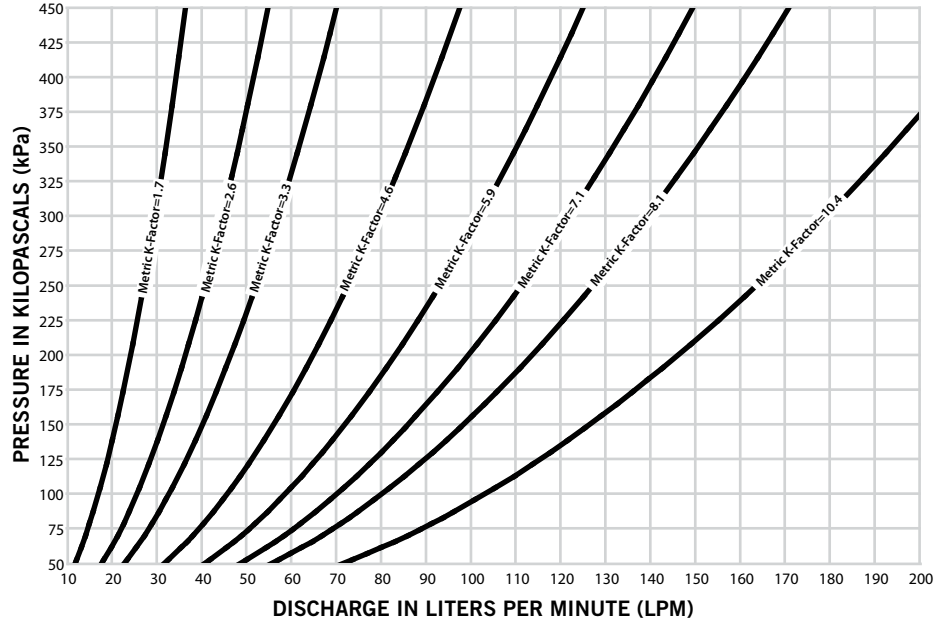

K-factors have tolerances of +/- 0.2 GPM/ $\sqrt{\text{PSI}}$  (0.2 LPM/ $\sqrt{\text{kPa}}$ ) from nominal.

V12

Open Spray Nozzles

STYLE V12

INSTALLATION TECHNICAL DATA

FIGURE 5 – DESIGN SPRAY PROFILES (METRIC, ALL K FACTORS)

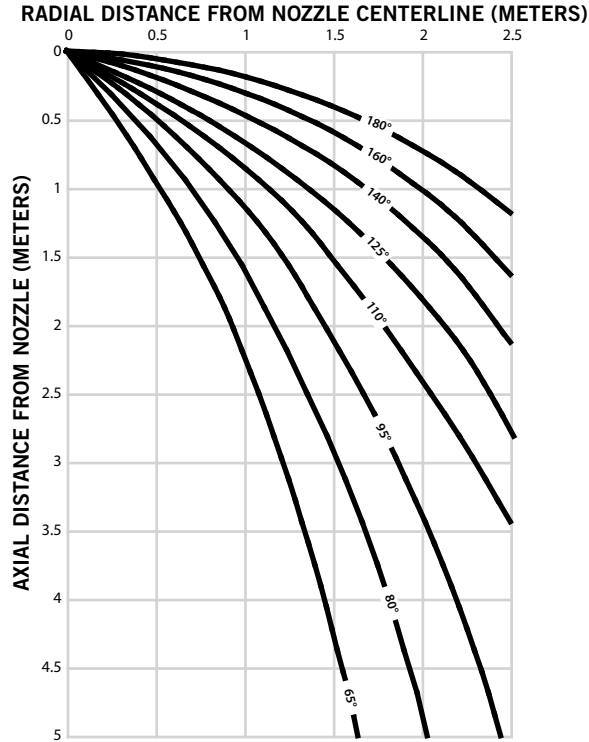

Notes:

- 1) The design spray profile is the included angle of discharge for each nozzle.
- 2) Figure 2 illustrates the radial distance at various heights based upon testing in the pendent position at 10 psi, 20 psi, and 60 psi / 69 kPa, 138 kPa, and 414 kPa discharge pressure (see Figure 3, Variable C).
- 3) For FM only installations, use a recommended tolerance of +/- 2 ft [0.6 m] from nominal for the radial distances shown (x-axis) in Figure 2 for all fixed angle orientations. Use a recommended spray profile angle tolerance of +/- 5° in the pendent position (vertically downward) and +/-10° in all other fixed angle orientations.
- 4) For UL/NFPA only installations, use a recommended tolerance of +/-15% from nominal for the radial distances shown (x-axis) in Figure 2 for all fixed angle orientations.
- 5) Spray profiles will tend to decrease (or pull inward) with an increase in pressure. All test data was obtained in a stagnant air environment.

See Exposure Protection Tables for fixed angle orientation and maximum axial distance from the plane of protection for each model.



V12

Open Spray Nozzles

STYLE V12

INSTALLATION TECHNICAL DATA  
EXPOSURE PROTECTION TABLES  
(METRIC)

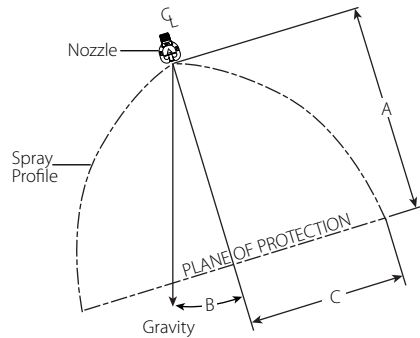

A – Axial Distance  
B – Fixed Angle (Orientation)  
C – Radial Distance

FIGURE 6 – SPRAY COVERAGE VARIABLES

MAXIMUM AXIAL DISTANCE FOR 65° SPRAY ANGLE IN METERS

Fixed Angle	K FACTOR							
	1,7	2,6	3,3	4,6	5,9	7,1	8,1	10,4
0°	4,5	4,6	4,6	4,6	4,6	4,7	4,8	4,9
30°	3,0	3,0	3,0	3,1	3,2	3,4	3,4	3,5
45°	2,4	2,4	2,6	2,7	2,8	3,0	3,0	3,1
60°	2,1	2,2	2,4	2,5	2,6	2,7	2,7	2,9
90°	2,0	2,1	2,1	2,3	2,4	2,4	2,4	2,6
120°	1,9	2,0	2,1	2,2	2,2	2,3	2,3	2,4
135°	1,8	1,8	1,9	2,0	2,1	2,1	2,1	2,3
150°	1,7	1,8	1,8	1,8	2,0	2,1	2,1	2,2
180°	1,5	1,5	1,6	1,7	1,8	2,0	2,0	2,1

MAXIMUM AXIAL DISTANCE FOR 80° SPRAY ANGLE IN METERS

Fixed Angle	K FACTOR							
	1,7	2,6	3,3	4,6	5,9	7,1	8,1	10,4
0°	4,5	4,6	4,6	4,6	4,6	4,8	4,8	4,9
30°	2,9	3,0	3,1	3,2	3,3	3,3	3,4	3,4
45°	2,3	2,4	2,5	2,6	2,7	2,7	2,8	3,0
60°	1,9	2,0	2,1	2,1	2,2	2,3	2,5	2,7
90°	1,8	1,9	2,0	2,1	2,1	2,2	2,3	2,4
120°	1,6	1,7	1,8	1,8	1,9	1,9	2,0	2,1
135°	1,4	1,6	1,7	1,8	1,8	1,8	1,9	2,0
150°	1,3	1,4	1,4	1,7	1,8	1,8	1,8	1,8
180°	1,2	1,3	1,4	1,6	1,7	1,7	1,8	1,8

MAXIMUM AXIAL DISTANCE FOR 95° SPRAY ANGLE IN METERS

Fixed Angle	K FACTOR							
	1,7	2,6	3,3	4,6	5,9	7,1	8,1	10,4
0°	4,5	4,6	4,6	4,6	4,6	4,7	4,8	4,9
30°	2,5	2,6	2,8	2,9	3,1	3,2	3,2	3,4
45°	2,1	2,1	2,2	2,3	2,6	2,7	2,7	3,0
60°	1,6	1,7	1,8	2,0	2,1	2,1	2,3	2,6
90°	1,4	1,4	1,7	1,8	1,8	1,8	1,9	2,1
120°	1,2	1,3	1,4	1,5	1,6	1,7	1,7	1,8
135°	1,1	1,1	1,3	1,4	1,5	1,6	1,6	1,7
150°	1,0	1,1	1,1	1,4	1,4	1,4	1,5	1,6
180°	0,9	1,0	1,0	1,2	1,3	1,3	1,4	1,4

MAXIMUM AXIAL DISTANCE FOR 110° SPRAY ANGLE IN METERS

Fixed Angle	K FACTOR							
	1,7	2,6	3,3	4,6	5,9	7,1	8,1	10,4
0°	2,9	3,0	3,0	3,0	3,0	3,2	3,3	3,4
30°	2,0	2,1	2,2	2,4	2,6	2,7	2,7	2,9
45°	1,7	1,8	2,1	2,1	2,3	2,4	2,5	2,6
60°	1,4	1,5	1,7	1,8	1,9	2,1	2,2	2,4
90°	1,1	1,2	1,4	1,4	1,6	1,7	1,8	1,9
120°	1,0	1,1	1,2	1,3	1,4	1,4	1,4	1,6
135°	0,8	0,9	1,1	1,2	1,3	1,3	1,4	1,4
150°	0,8	0,8	1,0	1,1	1,2	1,3	1,3	1,4
180°	0,7	0,8	0,9	1,0	1,1	1,1	1,2	1,3

MAXIMUM AXIAL DISTANCE FOR 125° SPRAY ANGLE IN METERS

Fixed Angle	K FACTOR							
	1,7	2,6	3,3	4,6	5,9	7,1	8,1	10,4
0°	2,4	2,4	2,4	2,4	2,5	2,5	2,6	2,7
30°	1,5	1,6	1,7	1,8	2,1	2,2	2,4	2,4
45°	1,3	1,4	1,4	1,5	1,8	1,9	2,0	2,1
60°	1,1	1,1	1,2	1,3	1,6	1,7	1,8	1,9
90°	0,9	1,0	1,1	1,1	1,3	1,4	1,4	1,6
120°	0,6	0,6	0,8	1,0	1,1	1,1	1,1	1,3
135°	0,5	0,5	0,7	0,9	1,1	1,1	1,1	1,1
150°	0,5	0,5	0,7	0,8	0,9	1,0	1,0	1,1
180°	0,4	0,5	0,6	0,8	0,8	0,8	0,9	1,0

MAXIMUM AXIAL DISTANCE FOR 140° SPRAY ANGLE IN METERS

Fixed Angle	K FACTOR							
	1,7	2,6	3,3	4,6	5,9	7,1	8,1	10,4
0°	1,9	1,9	1,9	2,0	2,0	2,0	2,1	2,1
30°	1,1	1,1	1,3	1,4	1,6	1,6	1,7	1,8
45°	0,9	1,0	1,1	1,3	1,4	1,5	1,5	1,6
60°	0,7	0,8	0,8	1,1	1,3	1,3	1,4	1,4
90°	0,6	0,6	0,8	0,9	1,1	1,1	1,1	1,2
120°	0,5	0,5	0,7	0,8	0,8	0,8	0,9	1,1
135°	0,5	0,5	0,5	0,7	0,8	0,8	0,8	0,9
150°	0,4	0,4	0,5	0,5	0,6	0,6	0,7	0,8
180°	0,3	0,3	0,4	0,5	0,5	0,5	0,6	0,7

MAXIMUM AXIAL DISTANCE FOR 160° SPRAY ANGLE IN METERS

Fixed Angle	K FACTOR							
	1,7	2,6	3,3	4,6	5,9	7,1	8,1	10,4
0°	1,4	1,4	1,4	1,5	1,5	1,5	1,6	1,6
30°	1,1	1,1	1,2	1,2	1,4	1,4	1,4	1,4
45°	0,9	0,9	1,1	1,1	1,2	1,2	1,2	1,3
60°	0,6	0,6	0,7	0,8	1,0	1,0	1,1	1,1
90°	0,3	0,4	0,5	0,6	0,8	0,8	0,8	0,8
120°	NR	0,3	0,5	0,5	0,6	0,7	0,7	0,8
135°	NR	NR	0,3	0,5	0,5	0,5	0,5	0,6
150°	NR	NR	NR	0,3	0,4	0,4	0,5	0,5
180°	NR	NR	NR	0,3	0,3	0,3	0,4	0,5

MAXIMUM AXIAL DISTANCE FOR 180° SPRAY ANGLE IN METERS

Fixed Angle	K FACTOR							
	1,7	2,6	3,3	4,6	5,9	7,1	8,1	10,4
0°	1,0	1,0	1,0	1,1	1,1	1,1	1,1	1,1
30°	0,7	0,7	0,8	0,8	0,9	1,0	1,0	1,0
45°	0,6	0,6	0,7	0,8	0,8	0,9	0,9	0,9
60°	0,5	0,5	0,5	0,6	0,7	0,7	0,8	0,8
90°	NR	NR	0,3	0,3	0,5	0,5	0,5	0,7
120°	NR	NR	0,3	0,3	0,4	0,5	0,5	0,5
135°	NR	NR	NR	0,3	0,3	0,4	0,4	0,5
150°	NR	NR	NR	NR	0,3	0,3	0,4	0,4
180°	NR	NR	NR	NR	NR	0,3	0,3	0,3

## V12

Open Spray Nozzles

### STYLE V12

---

#### WARRANTY

Refer to the Warranty section of the current Price List or contact Victaulic for details.

---

#### NOTE

This product shall be manufactured by Victaulic or to Victaulic specifications. All products to be installed in accordance with current Victaulic installation/assembly instructions. Victaulic reserves the right to change product specifications, designs and standard equipment without notice and without incurring obligations.

---

#### ORDERING INFORMATION

Please specify the following when ordering:

- Sprinkler Model Number
- K Factor
- Spray Angle
- Nozzle Finish
- Wrench Model Number

---

For complete contact information, visit [www.victaulic.com](http://www.victaulic.com)

40.96 5033 REV B UPDATED 05/2009

VICTAULIC IS A REGISTERED TRADEMARK OF VICTAULIC COMPANY. © 2009 VICTAULIC COMPANY. ALL RIGHTS RESERVED.

40.96

