

FireLock NXT™ Deluge Valve



ME: 248-98-E

CSFM: 7770-0531-117

SERIES 769

With Deluge Trim
Grooved x Grooved

The patent-pending Victaulic Series 769 FireLock NXT Deluge Valve controls the water supply entry into the deluge system piping and open sprinklers. The Series 769 is a low differential, latched clapper valve that uses a unique direct acting diaphragm to separate system water supplies from deluge pipe sprinkler systems.

* see page 16-18 for European configurations.



PATENT PENDING

FEATURES

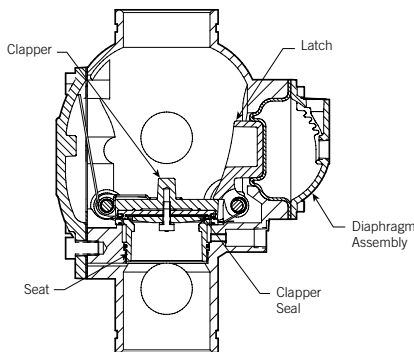

Exaggerated for Clarity

NOTE: Valve is shown in the “set” position

Victaulic Series 769 Deluge Valves feature a high-strength, low-weight, ductile iron body with pneumatic, hydraulic, and electric actuation methods. The straight-through body design provides superior flow and low-pressure drop. It offers simple access to all internal parts for easy maintenance. All internal parts are replaceable. The valve is painted inside and out to increase corrosion resistance.

Maintenance and service can be performed from the installed position. The rubber clapper seal is replaced easily without removing the clapper from the valve. The body is tapped for main drain and all available trim configurations. The low differential, unique latch and actuator design of the valve allows the device to be reset without opening the valve. The low differential design is not subject to water columns. The system can only be installed in a vertical configuration.

The valve allows the water to operate a water motor alarm and/or electric pressure alarms, which continue until the flow of water stops.

The valve can be configured for wet pilot, dry pilot or electrical activation.

The valve is rated to 300psi/2065 kPa water working pressure and is factory tested hydrostatically to 600psi/4135 kPa for sizes 1 1/2 – 8”/40 – 200mm. VDS trim configurations are approved to 16 BAR. Other European trim configurations are approved to 20 BAR. (see page 16-18). Required air pressure is 13psi/90 kPa.

The Series 769 is available grooved x grooved. Standard grooved dimensions conform to ANSI/AWWA C606.

Installation Options

The Victaulic Series 769 FireLock NXT Deluge Valve is available bare, or in the following configurations: (note: trim kits may be ordered separately)

Pre-trimmed

The pre-trimmed valve comes completely assembled with all necessary trim components.

Vic-Quick Riser

The Vic-Quick Riser comes completely pre-trimmed and includes a shut off valve (uses a Series 705W FireLock Butterfly valve – request publication 10.18; for 1 1/2 and 2”/40 and 50mm sizes, the Vic-Quick Riser comes with a Series 728 Ball Valve – request publication 10.17) for system shut off, pressure switches, and a drain kit for ease of installation. For complete Vic-Quick Riser information request publication 30.20.

Series 745 FireLock Fire-Pac (North America only)

The Fire-Pac is a completely pre-assembled fire protection valve that provides maximum service in a minimal enclosed space. The unit includes a water supply shutoff valve, the sprinkler system fire protection valve, alarm line pressure switches, air supervisory pressure switches, supervisory pump switches, and digital pressure gauges that are easily viewed through a window in the cabinet door. For complete Fire-Pac information request publication 30.23.

Optional accessories ship separately.

JOB/OWNER

System No. _____

Location _____

CONTRACTOR

Submitted By _____

Date _____

ENGINEER

Spec Sect _____ Para _____

Approved _____

Date _____

www.victaulic.com

VICTAULIC IS A REGISTERED TRADEMARK OF VICTAULIC COMPANY. © 2008 VICTAULIC COMPANY. ALL RIGHTS RESERVED.

REV_E



FireLock NXT™ Deluge Valve

SERIES 769

With Deluge Trim
Grooved x Grooved

DIMENSIONS

THE 4"/114.3 MM DRY PILOT CONFIGURATION IS SHOWN BELOW
 1½ - 2"/48.3 - 60.3 MM CONFIGURATIONS CONTAIN ¾"/19 MM DRAIN VALVES.
 2½ - 3"/73.0 - 88.9 MM CONFIGURATIONS CONTAIN 1¼"/31 MM DRAIN VALVES.
 4 - 8"/114.3 - 219.1 MM CONFIGURATIONS CONTAIN 2"/50 MM DRAIN VALVES.

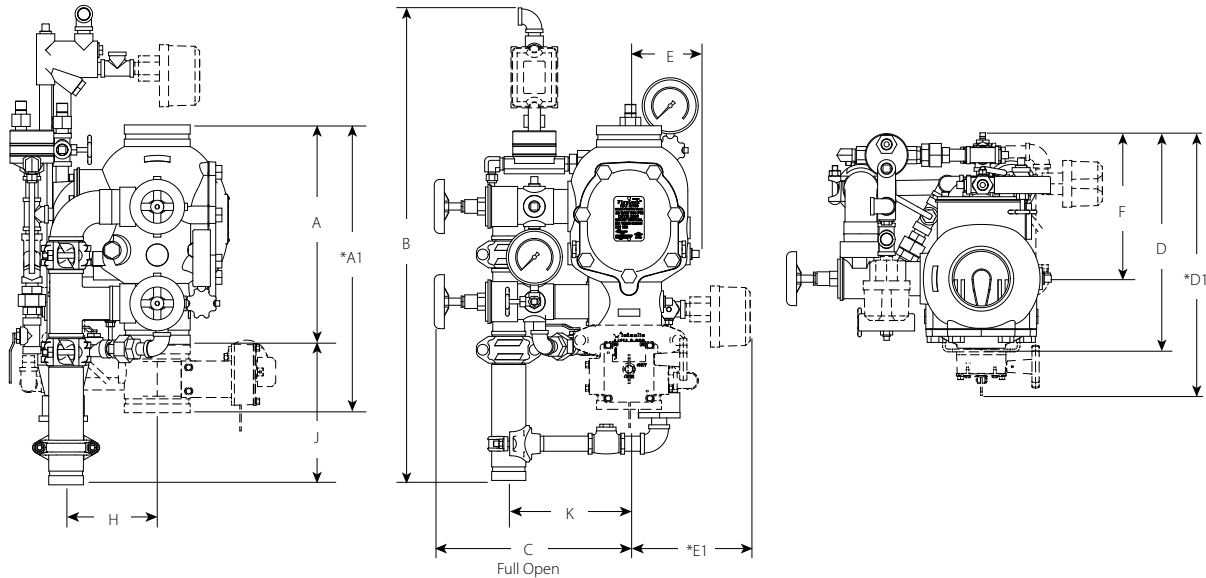

Size		Dimensions – inches/mm												Aprx. Weight Ea. lbs/kg	
Nominal Size Inches/mm	Actual Outside Diameter Inches/mm	A	A1*	B	C	D	D1*	E	E1*	F	H	J	K	Without Trim	With Trim
1½ 40	1.900 48.3	9.00 228.60	16.43 417.32	28.50 723	13.75 349	12.50 317	15.00 381	5.25 133	8.50 215	9.25 234	3.04 77.21	9.17 232.91	6.98 177.29	16.7 7.6	43.0 19.5
2 50	2.375 60.3	9.00 228.60	16.43 417.32	28.50 723	13.75 349	12.50 317	15.00 381	5.25 133	8.50 215	9.25 234	3.04 77.21	9.17 232.91	6.98 177.29	17.0 7.7	43.0 19.5
2½** 65**	2.875 73.0	12.61 320.29	16.50 419.10	32.25 819	13.50 342	13.50 342	17.50 444	5.25 133	9.00 228	9.25 234	3.90 99.06	10.50 266.70	6.93 176.02	41.0 18.7	65.0 29.5
76.1 mm	3.000 76.1	12.61 320.29	16.50 419.10	32.25 819	13.50 342	13.50 342	17.50 444	5.25 133	9.00 228	9.25 234	3.90 99.06	10.50 266.70	6.93 176.02	41.0 18.7	65.0 29.5
3 80	3.500 88.9	12.61 320.29	16.50 419.10	32.25 819	13.50 342	13.50 342	17.50 444	5.25 133	9.00 228	9.25 234	3.90 99.06	10.50 266.70	6.93 176.02	41.0 18.7	65.0 29.5
4 100	4.500 114.3	15.03 381.76	19.78 502.41	33.50 850	15.00 381	15.75 400	20.50 520	5.50 139	9.00 228	10.75 273	6.25 158.75	9.62 244.34	8.46 214.88	59.0 26.7	95.0 43.0
165.1 mm	6.500 165.1	16.00 406.40	22.00 558.80	33.75 857	15.50 393	16.75 425	22.00 558	6.00 152	8.50 215	11.25 285	6.20 157.48	9.62 244.34	8.84 224.53	80.0 36.2	116.0 52.6
6 150	6.625 168.3	16.00 406.40	22.00 558.80	33.75 857	15.50 393	16.75 425	22.00 558	6.00 152	8.50 215	11.25 285	6.20 157.48	9.62 244.34	8.84 224.53	80.0 36.2	116.0 52.6
8 200	8.625 219.1	17.50 444.50	22.94 582.67	33.50 850	16.75 425	19.75 501	25.25 641	7.00 177	8.75 222	12.75 323	6.05 153.67	9.40 238.76	10.21 259.33	122.0 55.3	158.0 71.6

NOTES:

The drawings shown above reflect the dry pilot trim with Series 776 Low-Pressure Actuator. In addition, these dimensions can be applied to hydraulic (wet pilot) release and electric release trim.

The "A" dimension coupling and the optional sensor switch are not shown for clarity.

Components shown as dotted lines denote optional equipment

* Measurements denoted with an asterisk take optional equipment into account.

Optional drain connection kit is shown for reference and takeout dimensions.

** European trim configurations are not available in 2½"/65mm pipe sizes.

FireLock NXT™ Deluge Valve

SERIES 769

With Deluge Trim
Grooved x Grooved

PERFORMANCE

Hydraulic Friction Loss

The chart below expresses the flow of water at 65°F/18°C through a full open valve.

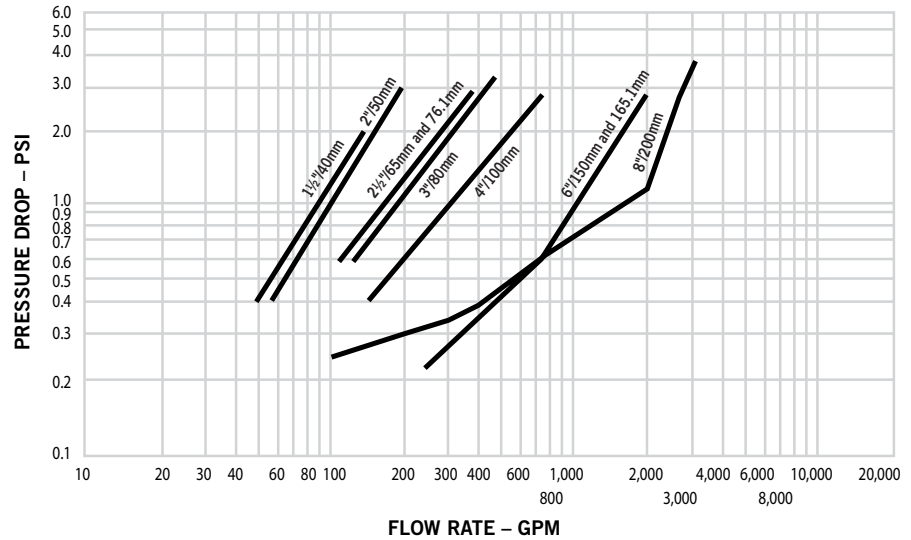

Frictional Resistance

The chart below expresses the frictional resistance of Victaulic Series 769 FireLock NXT Deluge Valve in equivalent feet of straight pipe.

Size		Equivalent Length of Pipe
Nominal Size Inches/mm	Actual Outside Dia. Inches/mm	Feet meters
1 1/2 40	1.900 48.3	3.00 0.914
2 50	2.375 60.3	9.00 2.743
2 1/2 65	2.875 73.0	8.00 2.438
76.1 mm	3.000 76.1	8.00 2.439
3 80	3.500 88.9	17.00 5.182
4 100	4.500 114.3	21.00 6.401
165.1 mm	6.500 165.1	22.00 6.706
6 150	6.625 168.3	22.00 6.706
8 200	8.625 219.1	50.00 15.240

FireLock NXT™ Deluge Valve

SERIES 769

With Deluge Trim
Grooved x Grooved

C_v VALUES

C_v values for flow of water at +60°F/+16°C through a fully open valve are shown in the table below.

Formulas for C_v values:

$$\Delta P = \frac{Q^2}{C_v^2}$$

$$Q = C_v \times \sqrt{\Delta P}$$

Where:

Q = Flow (GPM)

ΔP = Pressure Drop (psi)

C_v = Flow Coefficient

Size		C _v /K _v (Fully Open Valve)
Nominal Size Inches/ mm	Actual Outside Dia. Inches/ mm	
1 ½ 40	1.900 48.3	60 52.0
2 50	2.375 60.3	110 95.0
2 ½ 65	2.875 73.0	180 156.0
76.1 mm	3.000 76.1	180 156.0
3 80	3.500 88.9	200 173.0
4 100	4.500 114.3	350 302.8
165.1 mm	6.500 165.1	1000 865.0
6 150	6.625 168.3	1000 865.0
8 200	8.625 219.1	1500 1300.0

OPERATION

The Victaulic Deluge System utilizes the Series 769 Actuated Valve to control the water supply’s entry into the deluge system’s piping and open sprinklers. The Series 769 Actuated Valve is constructed with a clapper, which has a replaceable rubber face. The clapper makes contact with the valve seat ring, which has access holes to the intermediate chamber of the valve. The clapper is contacted by the latch, which is contacted by the diaphragm. In the closed position, water supply pressure from upstream of the water supply control valve is maintained in the diaphragm chamber, which holds the clapper in the closed position. The water is maintained in the diaphragm by one of the system release mechanisms (pneumatic, hydraulic or electric). Upon detection of an actuating event of the deluge system, such as an actuated pilot sprinkler or heat detection, the water supply pressure in the diaphragm chamber is released. This release allows the latch to move to its open position, permitting the clapper to pivot freely, thus allowing water into the system. Water will flow from all open sprinklers in the piping. Also, water enters the intermediate chamber of the valve through the holes in the seat ring. The water flows from the intermediate chamber to the alarm line, which activates the system’s alarms. These alarms continue to sound until the flow of water is stopped.

Important Note: If air pressure in a pneumatic system is lost, a low air alarm (optional) will activate. If air pressure is not restored, the valve will actuate. If a pilot sprinkler in either a pneumatic or hydraulic system is damaged, the valve will actuate and water will flow from all open sprinklers in the deluge system. Water motor alarms and alarm pressure switches will activate.

Manual Operation

Any time the manual release handle is pulled, water will be released, and the valve will actuate, thus allowing water into the deluge system. Water motor alarms and alarm pressure switches will activate.

FireLock NXT™ Deluge Valve

SERIES 769

With Deluge Trim
Grooved x Grooved

MATERIAL SPECIFICATIONS

Body: Ductile iron conforming to ASTM A-536, grade 65-45-12. Ductile iron conforming to ASTM A-395, grade 65-45-15, is available upon special request.

Clapper: Aluminum bronze UNS-C95500

Latch: Aluminum bronze UNS-C95500

Clapper Seal: Peroxide cured EPDM, ASTM D2000

Bushing and Seat O-rings: Nitrile

Springs: Stainless steel (300 Series)

Shafts: Stainless 17-4

Diaphragm: Peroxide cured EPDM with fabric reinforcement

Bill of Materials

- | | |
|--|--|
| 1 Valve Body | 12 Cover Plate |
| 2 Clapper | 13 Cover Plate Gasket |
| 3 Clapper Seal | 14 Cover Plate Bolts |
| 4 Seal Ring | 15 Latch |
| 5 Seal Washer | 16 Latch Spring |
| 6 Seal Retaining Ring | 17 Latch Shaft Bushing and O-Ring (Qty. 2) |
| 7 Seal Assembly Bolt | 18 Diaphragm |
| 8 Bolt Seal | 19 Diaphragm Cover |
| 9 Clapper Spring | 20 Diaphragm Cover Cap Screws (Qty. 8) |
| 10 Clapper Shaft | 21 Latch Shaft |
| 11 Clapper Shaft Bushing and O-Ring (Qty. 2) | |

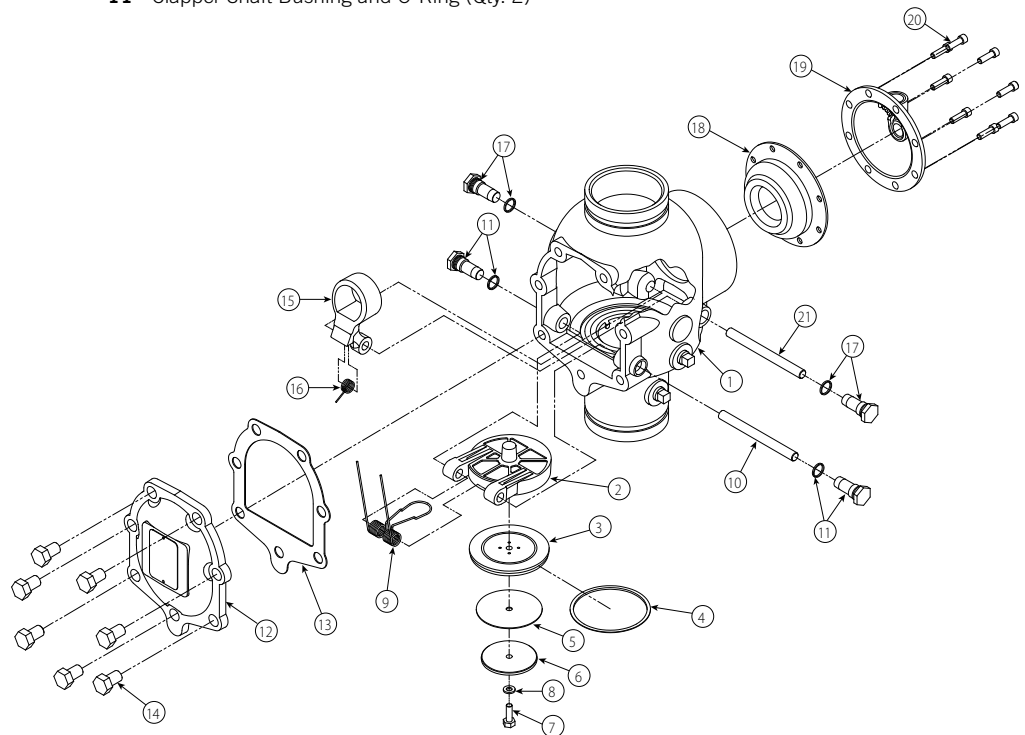

Exaggerated for clarity

FireLock NXT™ Deluge Valve

SERIES 769

With Deluge Trim
Grooved x Grooved

TRIM PACKAGES

Trim Package Options:

- 1 Pneumatic (Dry Pilot) Release
- 2 Hydraulic (Wet Pilot) Release
- 3 Electric Release

Trim packages include all required pipe and fittings. For trim package details and optional accessories, see pages 13-15. For European trim and optional accessory details, see pages 16-18.

Foam System Option:

Black Trim for Foam Systems – If the valve is intended for use in a foam system, black trim must be ordered, per NFPA requirements. Specify this requirement on the order.

Actuators:

- **Series 776 Low-Pressure Actuator** – The Series 776 Low-Pressure Actuator is pneumatically actuated and requires only 13 psi/90 kPa minimum air pressure, regardless of the system supply pressure. This actuator allows the system to operate with a low air or gas pressure of 7 psi/48 kPa. Request submittal 30.65.
- **Series 753-E Solenoid Valve** – The Series 753-E Solenoid Valve is designed for use with systems that require electrical activation. Request submittal 30.63.

Optional Accessories:

- **Series 760 Water Motor Alarm** – The Series 760 Water Motor Alarm is a mechanical device that sounds when a sustained flow of water occurs (such as with an open sprinkler). Request submittal 30.32.
- **Alarm Pressure Switch** – Alarm Pressure Switches are designed to activate electrical alarms and control panels when a sustained flow of water occurs (such as with an open sprinkler).
- **Air Supply System** – The air supply system contains all components for establishing and maintaining air in a pneumatic system. The compressor, low-pressure alarms, ball valves, and required trim are included in the air supply system.
- **Air Compressor** (See page 8 for more on the Victaulic Series 7C7 Compressor Package)
- **Air Maintenance Trim Assembly**
- **Alarm Panels**
- **Drain Connection Kit**

FireLock NXT™ Deluge Valve

SERIES 769

With Deluge Trim
Grooved x Grooved

AIR SUPPLY REQUIREMENTS FOR DRY PILOT DELUGE SYSTEMS

The required air pressure for Series 769 FireLock NXT Deluge Valves with dry pilot trim is 13 psi/ 90kPa, regardless of the system supply pressure.

If multiple Series 769 FireLock NXT Deluge Valves with dry pilot trim are installed with a common air supply, isolate the systems with a spring-loaded, soft-seated ball check valve to ensure air integrity for each system. Good practice is to include a ball valve for isolation and service of each individual system.

The engineer/system designer is responsible for sizing the compressor so that the entire system is charged to the required air pressure within 30 minutes. DO NOT oversize the compressor to provide more airflow. An oversized compressor will slow down or possibly prevent valve operation.

If the compressor fills the system too fast, it may be necessary to restrict the air supply. Restricting the air supply will ensure that air being exhausted from an open sprinkler or manual release valve is not replaced by the air supply system as fast as it is being exhausted

COMPRESSOR SIZING

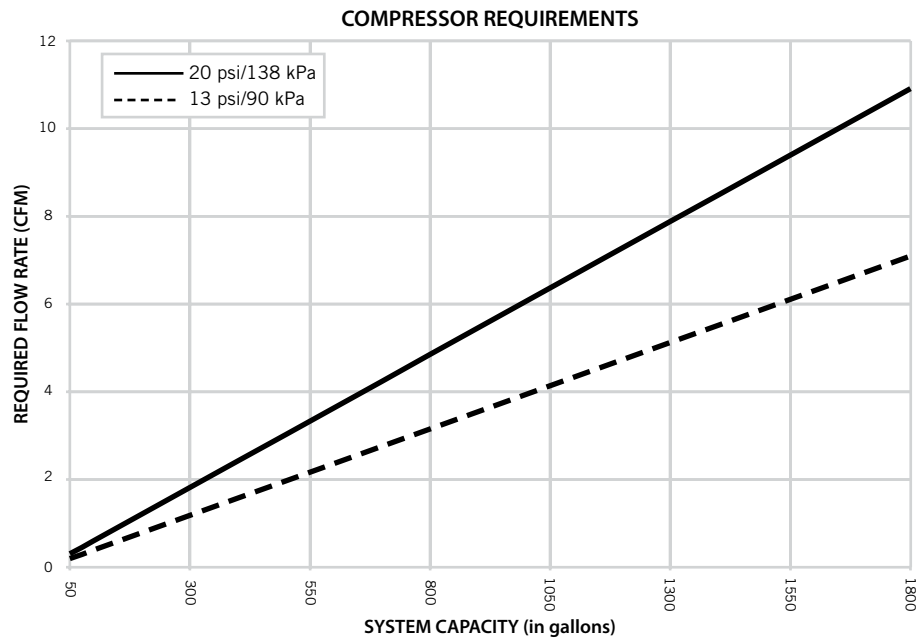

FireLock NXT™ Deluge Valve

SERIES 769

With Deluge Trim
Grooved x Grooved

BASE OR RISER-MOUNTED COMPRESSORS

For base or riser-mounted compressors, the recommended air pressure of 13 psi/90 kPa is the “on” or “low” pressure setting for the compressor. The “off” or “high” pressure setting should be 18 psi/124 kPa. Victaulic offers the Series 7C7 Compressor package for FireLock NXT devices which is riser-mounted and pre-set for the FireLock NXT pressure requirements as stated above. For information on the Series 7C7 package, consult publication 30.22. The Series 7C7 Compressor package is only available in North America.

When a base or riser-mounted air compressor supplies air to a Series 768 FireLock NXT Dry Valve, it is not necessary to install the Victaulic Series 757 Regulated Air Maintenance Trim Assembly (AMTA). In this case, the airline of the compressor connects to the trim at the fitting where the Series 757 Regulated AMTA is normally installed (refer to the applicable trim drawing). If the compressor is not equipped with a pressure switch, the Series 757P Air Maintenance Trim Assembly with Pressure Switch should be installed. For information on the Series 757 Regulated Air Maintenance Trim Assembly, see publication 30.35. For information on the Series 757P Air Maintenance Trim Assembly, see publication 30.36.

SHOP AIR OR TANK-MOUNTED AIR COMPRESSORS

In the event a compressor becomes inoperative, a properly sized tank-mounted air compressor provides the the greatest protection for systems.

When shop air or a tank-mounted air compressor or shop air system is used, the Series 757 Regulated AMTA must be installed. The Series 757 Regulated AMTA provides proper air regulation from the air reservoir to the sprinkler system.

For tank-mounted air compressors, the recommended air pressure of 13 psi/90 kPa should be used as the set point for the air regulator. The “on” pressure of the compressor should be at least 5 psi/ 34 kPa above the set point of the air regulator.

FireLock NXT™ Deluge Valve

SERIES 769

With Deluge Trim
Grooved x Grooved

SERIES 757 REGULATED AIR MAINTENANCE TRIM ASSEMBLY

NOTICE

- Victaulic recommends a maximum of two Series 769 FireLock NXT Deluge Valves with dry pilot trim per Series 757 Regulated AMTA.

Bill of Materials

- 1 1/8" 3.2 mm Restrictor
- 2 Slow Fill Ball Valve (Normally Open)
- 3 Air Regulator
- 4 Strainer (100 Mesh)
- 5 Spring-Loaded, Soft-Seated Ball Check Valve
- 6 Fast Fill Ball Valve (Normally Closed)

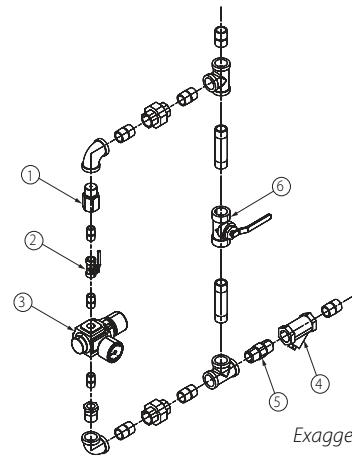

Exaggerated for clarity

SERIES 757P AIR MAINTENANCE TRIM ASSEMBLY WITH PRESSURE SWITCH

NOTICE

- Victaulic recommends a maximum of two Series 769 FireLock NXT Deluge Valves with dry pilot trim per Series 757P AMTA with Pressure Switch.

Bill of Materials

Item	Qty.	Description
1	1	Restrictor (1/2-inch NPT)
2	1	Strainer (1/2-inch NPT)
3	1	Swing Check (1/2-inch NPT)
4	1	Slow-Fill Ball Valve (Normally Open)
5	1	Spring-Loaded, Soft-Seated Check Valve
6	1	Pressure Switch
7	2	Compression Fitting, Straight (1/4-inch NPT x 1/4-inch Tube)
8	1	Copper Tubing (1/4-inch OD)
9	11	Close Nipple (1/2-inch NPT x 1.13)
10	1	Nipple (1/2-inch NPT x 4.00)
11	1	90° Female Elbow (1/2-inch NPT)
12	4	Female Tee (1/2-inch NPT)
13	3	Union (1/2-inch NPT)
14	2	Reducing Bushing (1/2-inch NPT x 1/4-inch NPT)
15	1	Fast-Fill Ball Valve (Normally Closed)
16	1	Pressure Switch Isolation Ball Valve (Normally Open - Lockable)

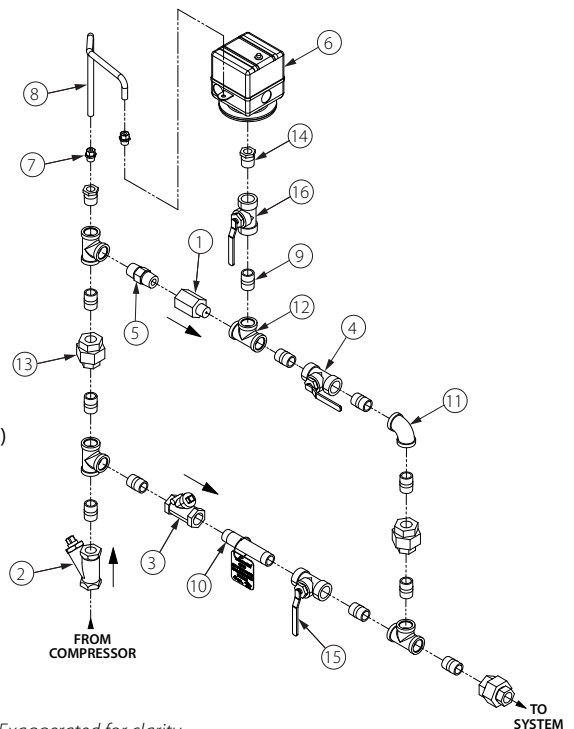

Exaggerated for clarity

FireLock NXT™ Deluge Valve

SERIES 769

With Deluge Trim
Grooved x Grooved

COMPRESSOR REQUIREMENTS

Settings for Air Supervisory Pressure Switches and Alarm Pressure Switches

Air supervisory pressure switches are required for dry systems and must be set according to the following instructions. **NOTE:** Switches for Vic-Quick Risers are pre-set at the factory.

Wire the air supervisory pressure switches to activate a low-pressure alarm signal. **NOTE:** In addition, the local authority having jurisdiction may require a high-pressure alarm. Contact the local authority having jurisdiction for this requirement.

Set the air supervisory pressure switches to activate at 2 – 4 psi (14 – 28 kPa) below the minimum air pressure required, but not lower than 10 psi/69 kPa.

Wire the alarm pressure switch to activate a water flow alarm.

Set the alarm pressure switch to activate on a pressure rise of 4 – 8 psi/28 – 55 kPa.

WET PILOT LINE CHARTS

Maximum allowable wet pilot line heights for specific equivalent lengths.

Heights are based on ½" schedule 40 pipe and a ½" sprinkler.

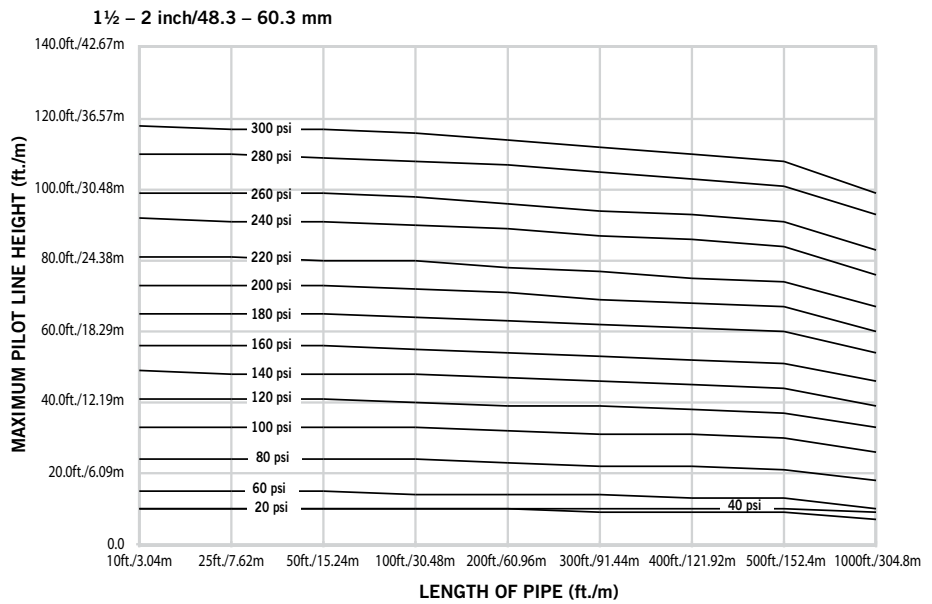

FireLock NXT™ Deluge Valve

SERIES 769

With Deluge Trim
Grooved x Grooved

WET PILOT LINE CHARTS

Maximum allowable wet pilot line heights for specific equivalent lengths.

Heights are based on ½" schedule 40 pipe and a ½" sprinkler.

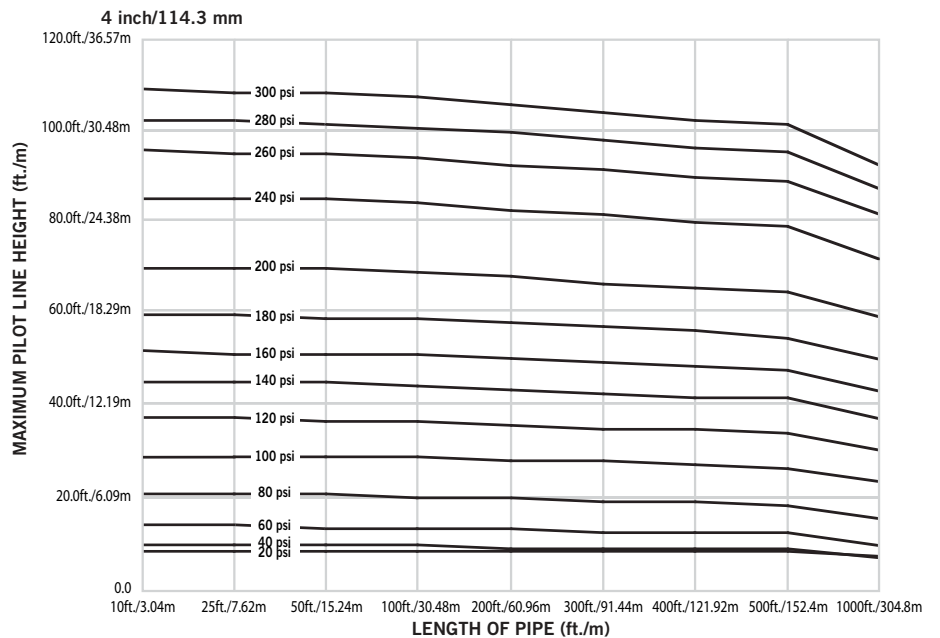
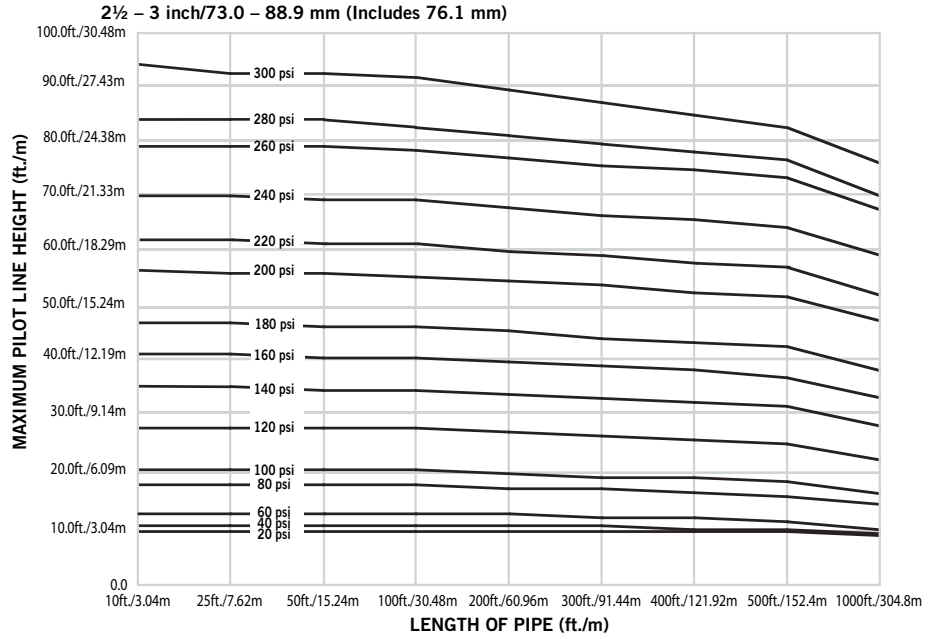

FireLock NXT™ Deluge Valve

SERIES 769

With Deluge Trim
Grooved x Grooved

WET PILOT LINE CHARTS

Maximum allowable wet pilot line heights for specific equivalent lengths.

Heights are based on ½" schedule 40 pipe and a ½" sprinkler.

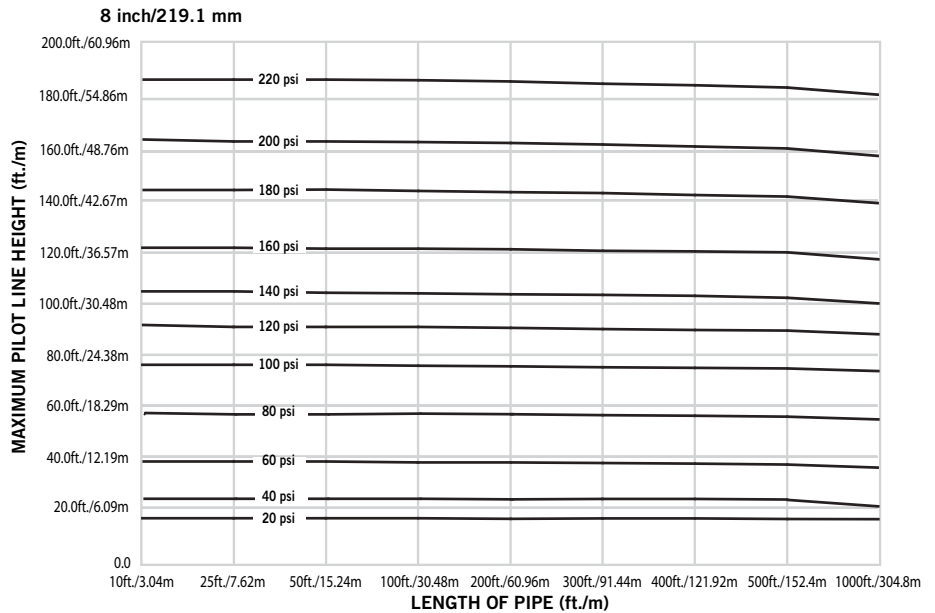
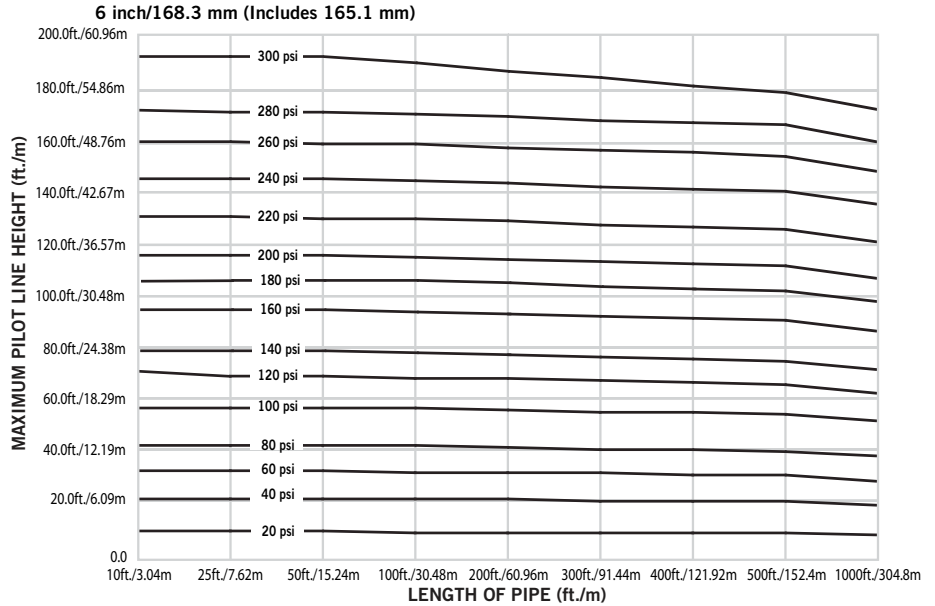

FireLock NXT™ Deluge Valve

SERIES 769

With Deluge Trim
Grooved x Grooved

PNEUMATIC RELEASE (DRY PILOT) DELUGE CONFIGURATION



Series 769 FireLock NXT Deluge Valve with
Pneumatic Release (Dry Pilot) Deluge Trim
(Optional Accessories Also Shown)

Bill of Materials

- 1 Series 769 FireLock NXT Deluge Valve
- 2 FireLock Rigid Coupling (Optional/Sold Separately – Comes Standard when VQR Assembly is Ordered)
- 3 Water Supply Main Control Valve (Optional/Sold Separately – Comes Standard when VQR Assembly is Ordered)
- 4 Drain Swing Check Valve
- 5 Drip Cup with Cap
- 6 Alarm Pressure Switch (Optional/Sold Separately – Comes Standard when VQR Assembly is Ordered)
- 7 Series 729 Drip Check Valve
- 8 Diaphragm-Charge-Line Ball Valve (Normally Open)
- 9 3-in-1 Strainer/Check/Restrictor Assembly
- 10 Series 760 Water Motor Alarm (Optional/Sold Separately)
- 11 Alarm Test Ball Valve
- 12 Diaphragm-Charge-Line Pressure Gauge (0-300 psi/0-2068 kPa/0-20.7 Bar)
- 13 Series 749 Auto Drain
- 14 Series 776 Low-Pressure Actuator
- 15 Air Manifold
- 16 Air Supervisory Pressure Switch (Optional/Sold Separately – Comes Standard when VQR Assembly is Ordered)
- 17 Water Supply Main Drain Valve - Flow Test
- 18 Water Supply Pressure Gauge (0-300 psi/0-2068 kPa/0-20.7 Bar)
- 19 Drain Connection Kit (Optional/Sold Separately – Comes Standard when VQR Assembly is Ordered)
- 20 System Main Drain Valve
- 21 Series 755 Manual Pull Station
- 22 Gauge Valve

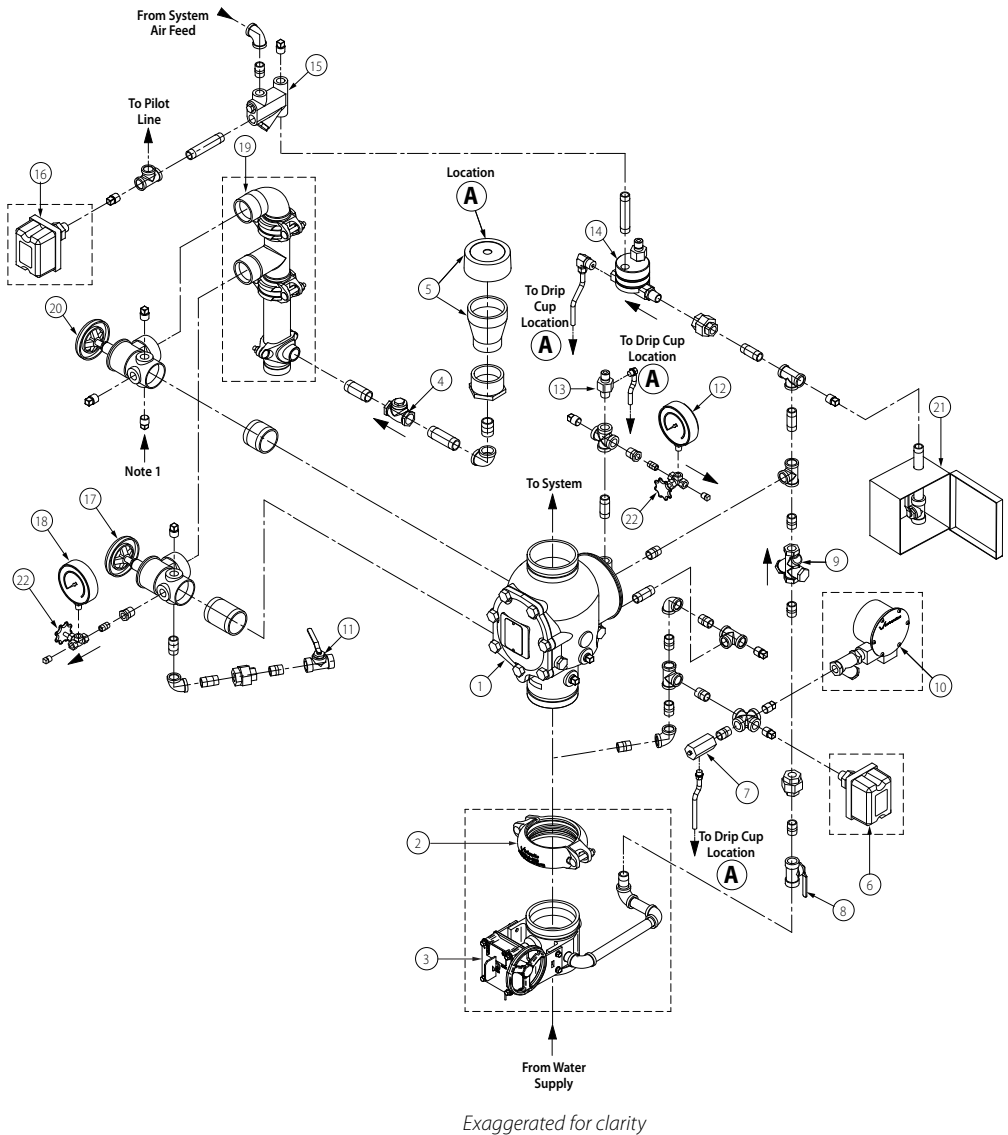

NOTE 1: Connection point for the Series 75D Water Column Device Kit

FireLock NXT™ Deluge Valve

SERIES 769

With Deluge Trim
Grooved x Grooved

HYDRAULIC RELEASE (WET PILOT) DELUGE CONFIGURATION



Series 769 FireLock NXT Deluge Valve with
Hydraulic Release (Wet Pilot) Deluge Trim
(Optional Accessories Also Shown)

Bill of Materials

- 1 Series 769 FireLock NXT Deluge Valve
- 2 FireLock Rigid Coupling (Optional/Sold Separately – Comes Standard when VQR Assembly is Ordered)
- 3 Water Supply Main Control Valve (Optional/Sold Separately – Comes Standard when VQR Assembly is Ordered)
- 4 Drain Swing Check Valve
- 5 Drip Cup with Cap
- 6 Alarm Pressure Switch (Optional/Sold Separately – Comes Standard when VQR Assembly is Ordered)
- 7 Series 729 Drip Check Valve
- 8 Diaphragm-Charge-Line Ball Valve (Normally Open)
- 9 3-in-1 Strainer/Check/Restrictor Assembly
- 10 Series 760 Water Motor Alarm (Optional/Sold Separately)
- 11 Alarm Test Ball Valve
- 12 Diaphragm-Charge-Line Pressure Gauge (0-300 psi/0-2068 kPa/0-20.7 Bar)
- 13 Series 749 AutoDrain
- 14 Water Supply Main Drain Valve – Flow Test
- 15 Water Supply Pressure Gauge (0-300 psi/0-2068 kPa/0-20.7 Bar)
- 16 Drain Connection Kit (Optional/Sold Separately – Comes Standard when VQR Assembly is Ordered)
- 17 System Main Drain Valve
- 18 Series 755 Manual Pull Station
- 19 Gauge Valve

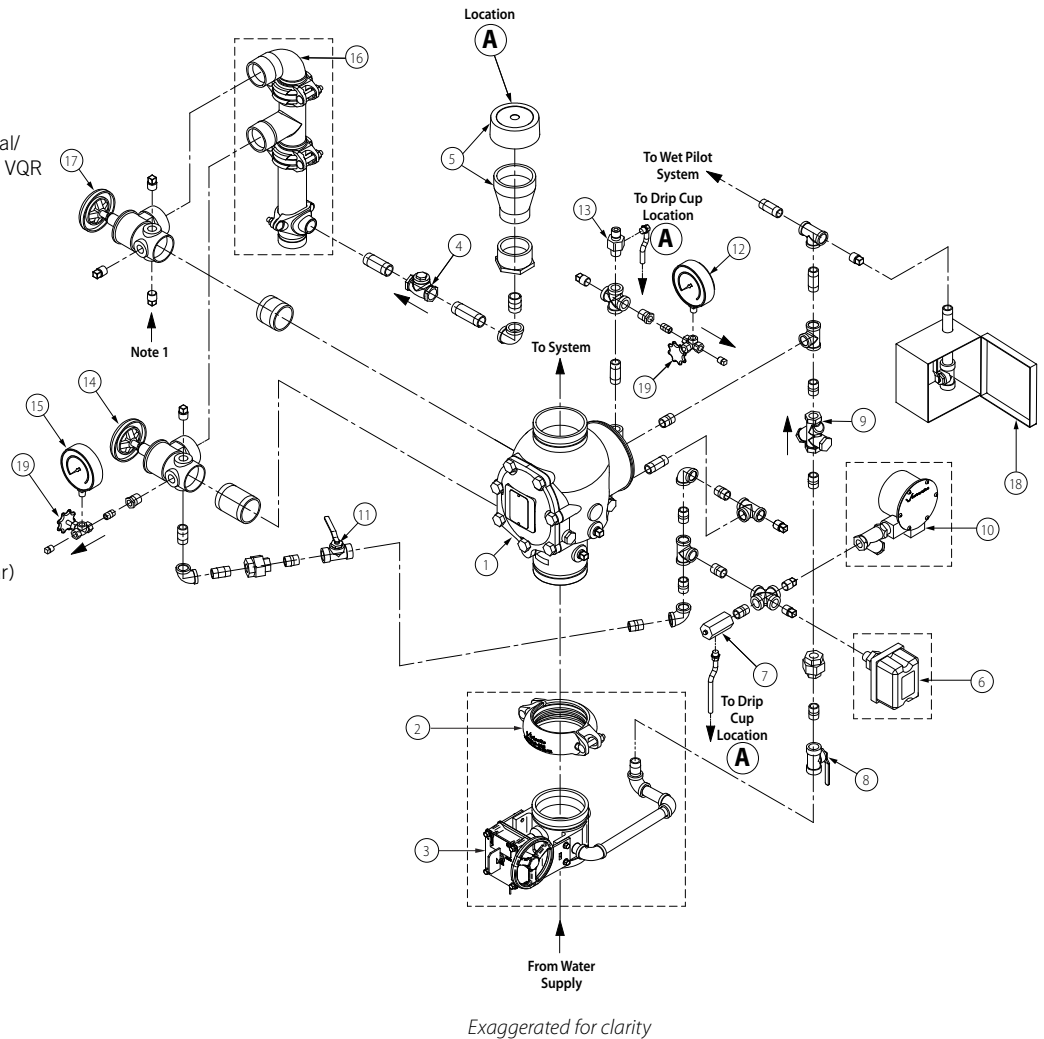

NOTE 1: Connection point for the Series 75D Water Column Device Kit

FireLock NXT™ Deluge Valve

SERIES 769

With Deluge Trim
Grooved x Grooved

ELECTRIC RELEASE CONFIGURATION



Series 769 FireLock NXT Deluge Valve with
Electric Release Trim
(Optional Accessories Also Shown)

Bill of Materials

- 1 Series 769 FireLock NXT Deluge Valve
- 2 FireLock Rigid Coupling (Optional/Sold Separately – Comes Standard when VQR Assembly is Ordered)
- 3 Water Supply Main Control Valve (Optional/Sold Separately – Comes Standard when VQR Assembly is Ordered)
- 4 Drain Swing Check Valve
- 5 Drip Cup with Cap
- 6 Alarm Pressure Switch (Optional/Sold Separately – Comes Standard when VQR Assembly is Ordered)
- 7 Series 729 Drip Check Valve
- 8 Diaphragm-Charge-Line Ball Valve (Normally Open)
- 9 3-in-1 Strainer/Check/Restrictor Assembly
- 10 Series 760 Water Motor Alarm (Optional/Sold Separately)
- 11 Alarm Test Ball Valve
- 12 Diaphragm-Charge-Line Pressure Gauge (0-300 psi/0-2068 kPa/0-20.7 Bar)
- 13 Series 749 AutoDrain
- 14 Water Supply Main Drain Valve – Flow Test
- 15 Water Supply Pressure Gauge (0-300 psi/0-2068 kPa/0-20.7 Bar)
- 16 Drain Connection Kit (Optional/Sold Separately – Comes Standard when VQR Assembly is Ordered)
- 17 Gauge Valve
- 18 System Main Drain Valve
- 19 Series 755 Manual Pull Station
- 20 Series 753-E Solenoid Valve

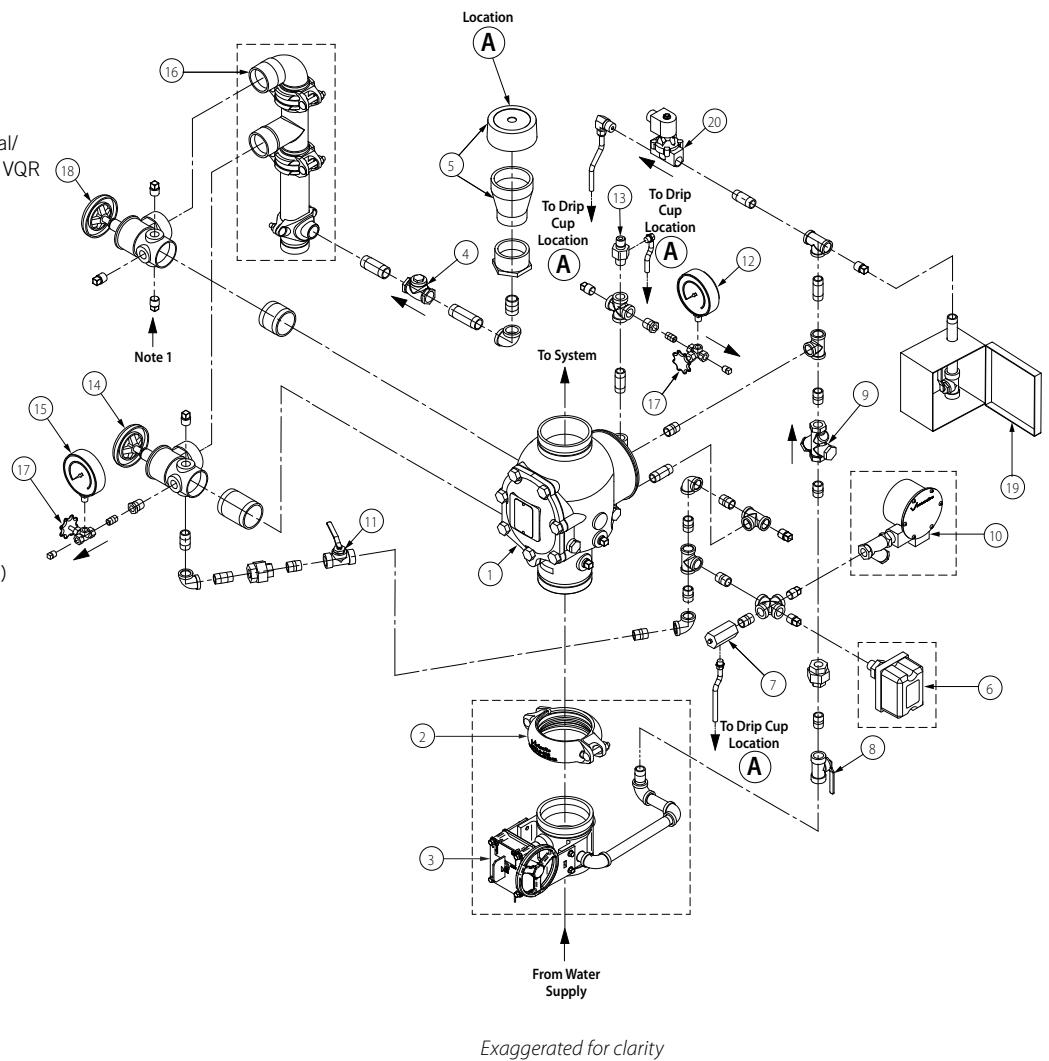

NOTE 1: Connection point for the Series 75D Water Column Device Kit

FireLock NXT™ Deluge Valve

SERIES 769

With Deluge Trim
Grooved x Grooved

DELUGE ELECTRIC EUROPEAN CONFIGURATION



Series 769 FireLock NXT Deluge Valve
(Optional Accessories Also Shown. Note: Only Vic-Quick Riser configuration is VdS approved.)

Bill of Materials

- 1 Series 769 FireLock NXT Deluge Valve
- 2 FireLock Rigid Coupling (Optional/Sold Separately – Comes Standard when VQR Assembly is Ordered)
- 3 Water Supply Main Control Valve (Optional/Sold Separately – Comes Standard when VQR Assembly is Ordered)
- 4 Drain Swing Check Valve
- 5 Drip Cup with Cap
- 6 Alarm Pressure Switch (Optional/Sold Separately – Comes Standard when VQR Assembly is Ordered)
- 7 Series 729 Drip Check Valve
- 8 Diaphragm-Charge-Line Ball Valve (Normally Open – Lockable)
- 9 3-in-1 Strainer/Check/Restrictor Assembly
- 10 Series 760 Water Motor Alarm (Optional/Sold Separately)
- 11 Alarm Test Ball Valve (Normally Closed – Lockable)
- 12 Diaphragm-Charge-Line Pressure Gauge (0-300 psi/0-2068 kPa/0-20.7 Bar)
- 13 Series 749 Auto Drain
- 14 Series 776 Low-Pressure Actuator
- 15 Air Manifold
- 16 Air Supervisory Pressure Switch (Optional/Sold Separately – Comes Standard when VQR Assembly is Ordered)
- 17 Water Supply Main Drain Valve - Flow Test
- 18 Water Supply Pressure Gauge (0-300 psi/0-2068 kPa/0-20.7 Bar)
- 19 Drain Connection Kit (Optional/Sold Separately – Comes Standard when VQR Assembly is Ordered)
- 20 System Main Drain Valve
- 21 Series 755 Manual Pull Station
- 22 Gauge Valve
- 23 Alarm Line Ball Valve (Normally Open – Lockable)
- 24 Water Motor Alarm Shutoff Valve (Normally Open – Lockable)*

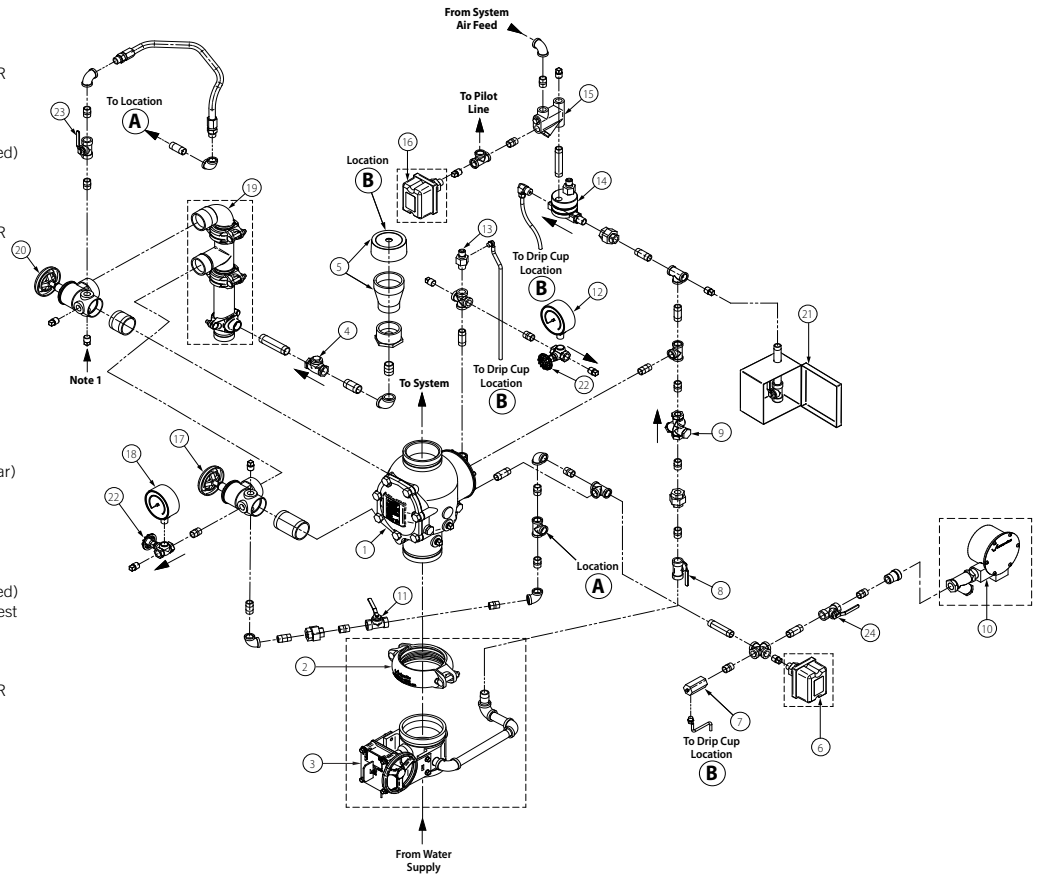

NOTE: VicQuick Riser must be specified for VdS approval.

FireLock NXT™ Deluge Valve

SERIES 769

With Deluge Trim
Grooved x Grooved

DELUGE DRY PILOT EUROPEAN CONFIGURATION



Series 769 FireLock NXT Deluge Valve
(Optional Accessories Also Shown Note: Only Vic-Quick Riser configuration is VdS approved.)

Bill of Materials

- 1 Series 769 FireLock NXT Deluge Valve
- 2 FireLock Rigid Coupling (Optional/Sold Separately – Comes Standard when VQR Assembly is Ordered)
- 3 Water Supply Main Control Valve (Optional/Sold Separately – Comes Standard when VQR Assembly is Ordered)
- 4 Drain Swing Check Valve
- 5 Drip Cup with Cap
- 6 Alarm Pressure Switch (Optional/Sold Separately – Comes Standard when VQR Assembly is Ordered)
- 7 Series 729 Drip Check Valve
- 8 Diaphragm-Charge-Line Ball Valve (Normally Open – Lockable)
- 9 3-in-1 Strainer/Check/Restrictor Assembly
- 10 Series 760 Water Motor Alarm (Optional/Sold Separately)
- 11 Alarm Test Ball Valve (Normally Closed – Lockable)
- 12 Diaphragm-Charge-Line Pressure Gauge (0-300 psi/0-2068 kPa/0-20.7 Bar)
- 13 Series 749 AutoDrain
- 14 Water Supply Main Drain Valve – Flow Test
- 15 Water Supply Pressure Gauge (0-300 psi/0-2068 kPa/0-20.7 Bar)
- 16 Drain Connection Kit (Optional/Sold Separately – Comes Standard when VQR Assembly is Ordered)
- 17 System Main Drain Valve
- 18 Series 755 Manual Pull Station
- 19 Gauge Valve
- 20 Alarm Line Ball Valve (Normally Open – Lockable)
- 21 Water Motor Alarm Shutoff Valve (Normally Open – Lockable)*

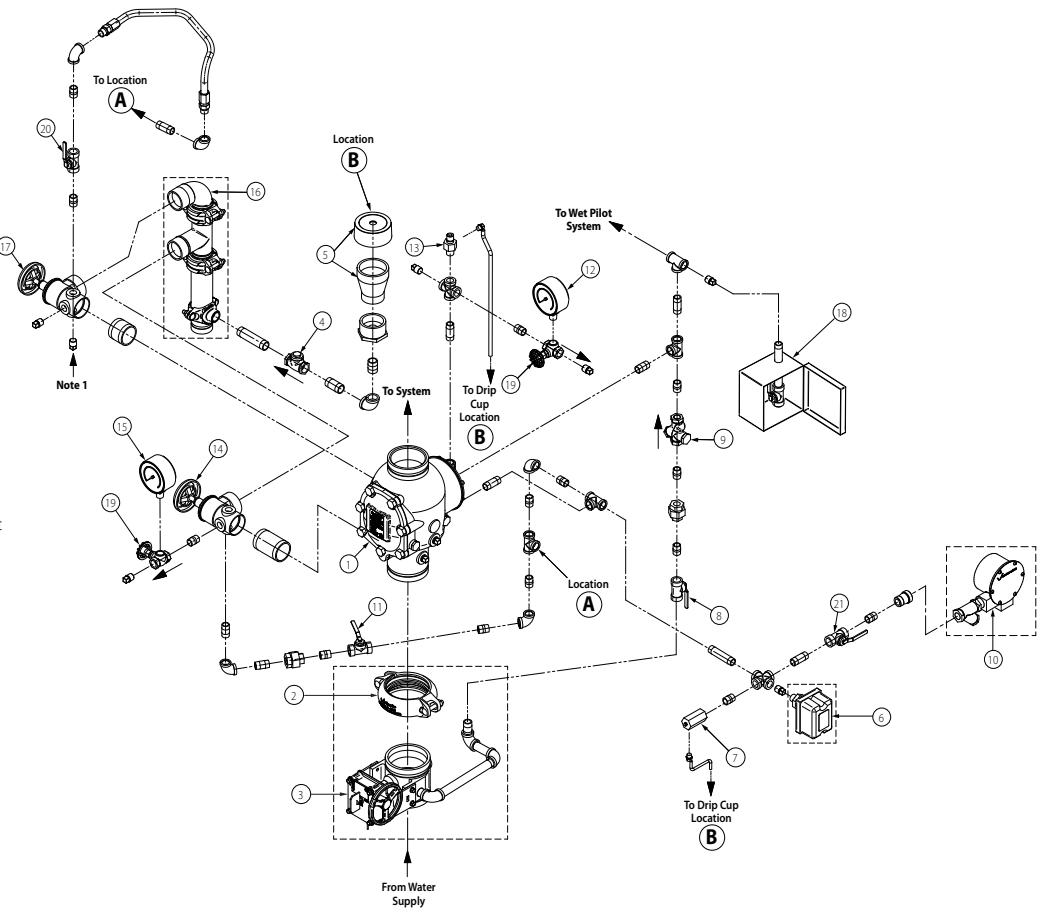

NOTE: VicQuick Riser must be specified for VdS approval.

FireLock NXT™ Deluge Valve

SERIES 769

With Deluge Trim
Grooved x Grooved

DELUGE WET PILOT EUROPEAN CONFIGURATION



Series 769 FireLock NXT Deluge Valve with
(Optional Accessories Also Shown Note: Only Vic-Quick Riser configuration is VdS approved.)

Bill of Materials

- 1 Series 769 FireLock NXT Deluge Valve
- 2 FireLock Rigid Coupling (Optional/Sold Separately – Comes Standard when VQR Assembly is Ordered)
- 3 Water Supply Main Control Valve (Optional/Sold Separately – Comes Standard when VQR Assembly is ordered)
- 4 Drain Swing Check Valve
- 5 Drip Cup with Cap
- 6 Alarm Pressure Switch (Optional/Sold Separately – Comes Standard when VQR Assembly is Ordered)
- 7 Series 729 Drip Check Valve
- 8 Diaphragm-Charge-Line Ball Valve (Normally Open – Lockable)
- 9 3-in-1 Strainer/Check/Restrictor Assembly
- 10 Series 760 Water Motor Alarm (Optional/Sold Separately)
- 11 Alarm Test Ball Valve (Normally Closed – Lockable)
- 12 Diaphragm-Charge-Line Pressure Gauge (0-300 psi/0-2068 kPa/0-20.7 Bar)
- 13 Series 749 AutoDrain
- 14 Water Supply Main Drain Valve – Flow Test
- 15 Water Supply Pressure Gauge (0-300 psi/0-2068 kPa/0-20.7 Bar)
- 16 Drain Connection Kit (Optional/Sold Separately – Comes Standard when VQR Assembly is Ordered)
- 17 Gauge Valve
- 18 System Main Drain Valve
- 19 Series 755 Manual Pull Station
- 20 Series 753-E Solenoid Valve
- 21 Alarm Line Ball Valve (Normally Open – Lockable)
- 22 Water Motor Alarm Shutoff Valve (Normally Open – Lockable)*

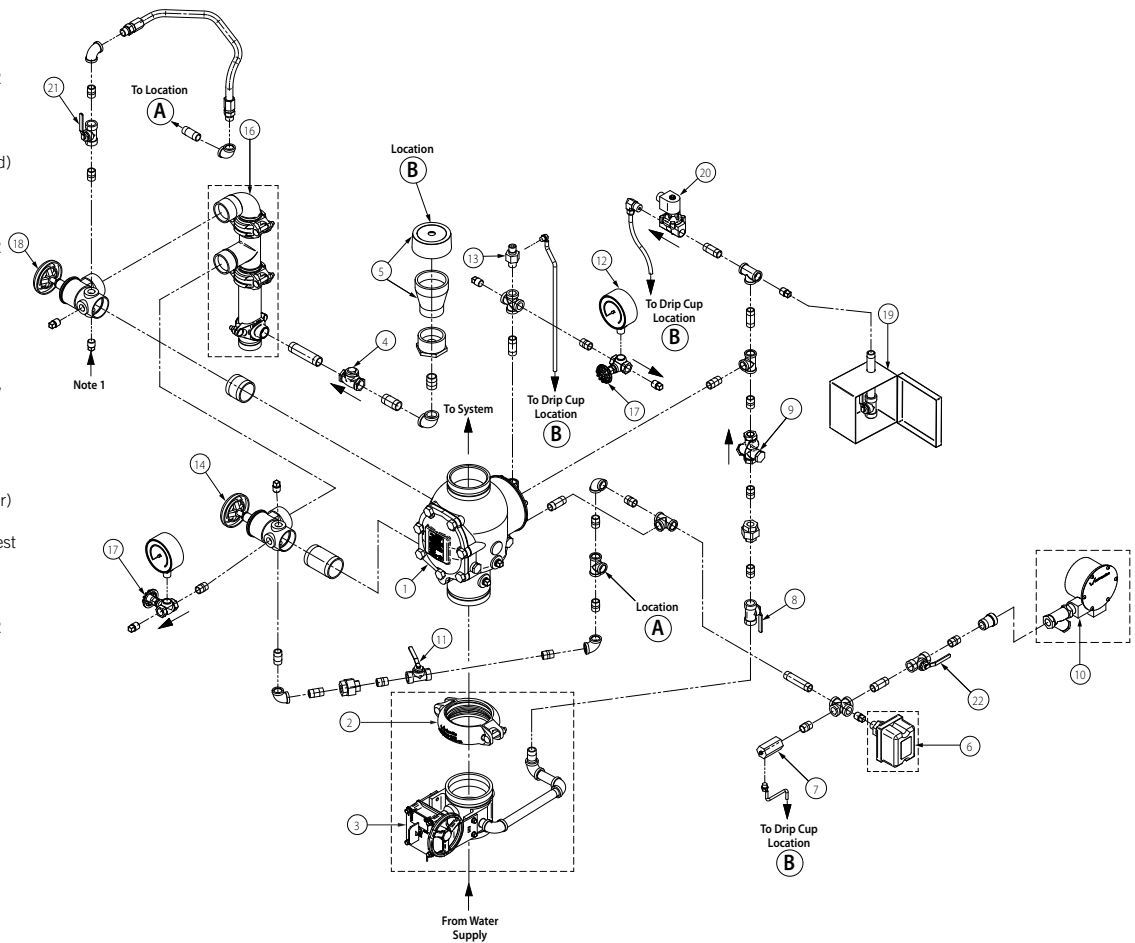

NOTE: VicQuick Riser must be specified for VdS approval.

FireLock NXT™ Deluge Valve

SERIES 769

With Deluge Trim
Grooved x Grooved

WARRANTY



Refer to the Warranty section of the current Price List or contact Victaulic for details.

NOTE

This product shall be manufactured by Victaulic or to Victaulic specifications. All products to be installed in accordance with current Victaulic installation/assembly instructions. Victaulic reserves the right to change product specifications, designs and standard equipment without notice and without incurring obligations.

WARNING



 WARNING	
	<ul style="list-style-type: none"> • This product must be installed by an experienced, trained installer, in accordance with the instructions provided with each valve. These instructions contain important information. <p>Failure to follow these instructions may result in serious personal injury, property damage, or valve leakage.</p> <p>If you need additional copies of this product literature or the valve installation instructions, or if you have any questions about the safe installation and use of this device, contact Victaulic Company, P.O. Box 31, Easton, PA 18044-0031 USA, Telephone: 001-610-559-3300.</p>



WCAS-7BCGUR

For complete contact information, visit www.victaulic.com

30.81 4221 REV E UPDATED 3/2008

VICTAULIC IS A REGISTERED TRADEMARK OF VICTAULIC COMPANY. © 2008 VICTAULIC COMPANY. ALL RIGHTS RESERVED.

